

**LOCATION:** Main St -- Mill Plain Blvd  
**CITY/STATE:** Vancouver, WA

**QC JOB #:** 13418613  
**DATE:** Thu, Jun 11 2015

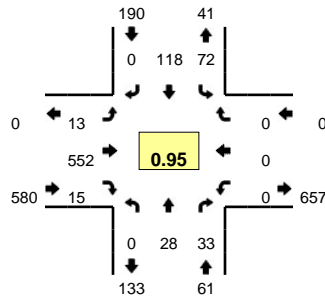

**Peak-Hour: 7:15 AM -- 8:15 AM**  
**Peak 15-Min: 7:40 AM -- 7:55 AM**

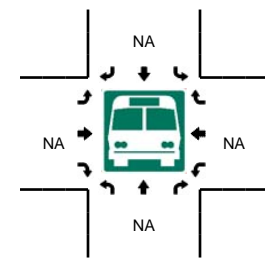
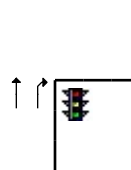
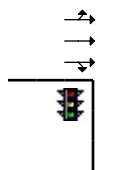
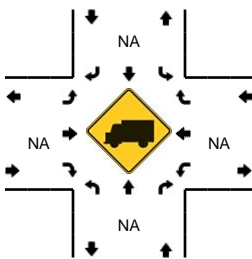
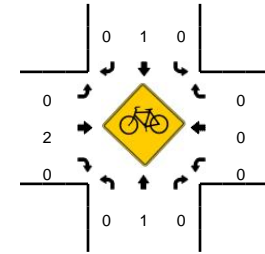
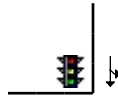
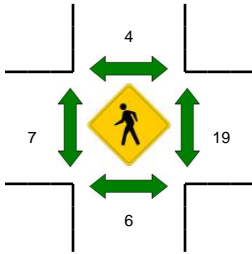
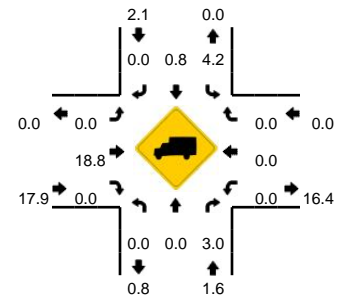

5-Min Count Period Beginning At	Main St (Northbound)				Main St (Southbound)				Mill Plain Blvd (Eastbound)				Mill Plain Blvd (Westbound)				Total	Hourly Totals
	Left	Thru	Right	U	Left	Thru	Right	U	Left	Thru	Right	U	Left	Thru	Right	U		
7:00 AM	0	3	1	0	9	6	0	0	0	35	0	0	0	0	0	0	54	
7:05 AM	0	2	1	0	6	8	0	0	0	36	1	0	0	0	0	0	54	
7:10 AM	0	1	0	0	6	8	0	0	0	41	0	0	0	0	0	0	56	
7:15 AM	0	3	1	0	8	10	0	0	1	55	1	0	0	0	0	0	79	
7:20 AM	0	1	1	0	9	7	0	0	0	61	0	0	0	0	0	0	79	
7:25 AM	0	3	6	0	10	9	0	0	2	29	0	0	0	0	0	0	59	
7:30 AM	0	1	1	0	2	6	0	0	0	45	0	0	0	0	0	0	55	
7:35 AM	0	2	3	0	8	12	0	0	1	35	1	0	0	0	0	0	62	
7:40 AM	0	3	1	0	9	10	0	0	0	51	2	0	0	0	0	0	76	
7:45 AM	0	1	5	0	5	14	0	0	1	47	3	0	0	0	0	0	76	
7:50 AM	0	3	5	0	6	16	0	0	1	31	4	0	0	0	0	0	66	
7:55 AM	0	3	3	0	4	10	0	0	3	43	1	0	0	0	0	0	67	783
8:00 AM	0	6	3	0	4	12	0	0	0	50	2	0	0	0	0	0	77	806
8:05 AM	0	1	1	0	3	8	0	0	3	48	0	0	0	0	0	0	64	816
8:10 AM	0	1	3	0	4	4	0	0	1	57	1	0	0	0	0	0	71	831
8:15 AM	0	7	5	0	8	13	0	0	1	36	2	0	0	0	0	0	72	824
8:20 AM	0	4	0	0	4	7	0	0	0	39	0	0	0	0	0	0	54	799
8:25 AM	0	5	4	0	5	8	0	0	0	35	2	0	0	0	0	0	59	799
8:30 AM	0	7	3	0	5	5	0	0	2	45	2	0	0	0	0	0	69	813
8:35 AM	0	1	0	0	3	2	0	0	1	39	1	0	0	0	0	0	47	798
8:40 AM	0	5	5	0	1	10	0	0	0	46	1	0	0	0	0	0	68	790
8:45 AM	0	7	3	0	1	15	0	0	1	43	3	0	0	0	0	0	73	787
8:50 AM	0	2	3	0	10	12	0	0	1	46	1	0	0	0	0	0	75	796
8:55 AM	0	2	3	0	1	21	0	0	0	31	1	0	0	0	0	0	59	788
Peak 15-Min Flowrates	Northbound				Southbound				Eastbound				Westbound				Total	
	Left	Thru	Right	U	Left	Thru	Right	U	Left	Thru	Right	U	Left	Thru	Right	U		
All Vehicles	0	28	44	0	80	160	0	0	8	516	36	0	0	0	0	0	872	
Heavy Trucks	0	0	4	0	4	0	0	0	0	84	0	0	0	0	0	0	92	
Pedestrians	4				4				8				4				20	
Bicycles	0	0	0		0	1	0		0	1	0		0	0	0		2	
Railroad																		
Stopped Buses																		

Comments: N/A