

LOCATION: Main St -- Mill Plain Blvd
CITY/STATE: Vancouver, WA

QC JOB #: 13418614
DATE: Thu, Jun 11 2015

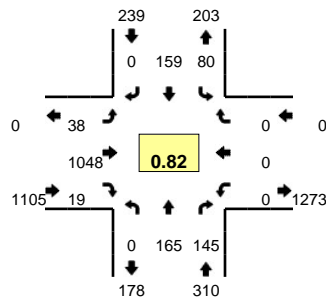

Peak-Hour: 4:30 PM -- 5:30 PM
Peak 15-Min: 5:00 PM -- 5:15 PM

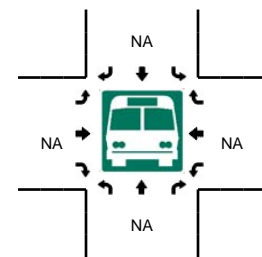
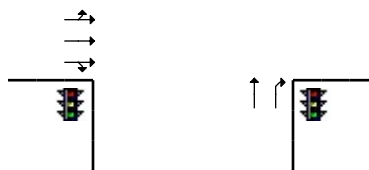
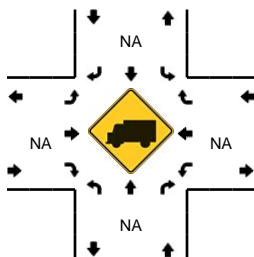
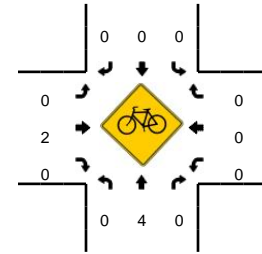
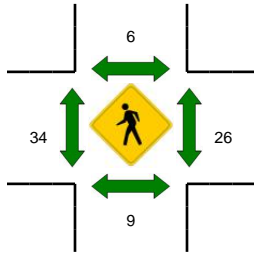
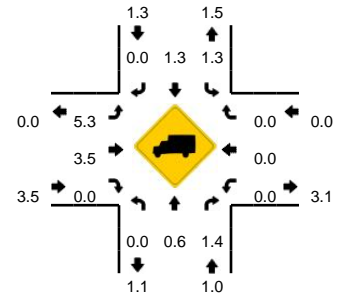

5-Min Count Period Beginning At	Main St (Northbound)				Main St (Southbound)				Mill Plain Blvd (Eastbound)				Mill Plain Blvd (Westbound)				Total	Hourly Totals
	Left	Thru	Right	U	Left	Thru	Right	U	Left	Thru	Right	U	Left	Thru	Right	U		
4:00 PM	0	13	10	0	4	14	0	0	2	77	0	0	0	0	0	0	120	
4:05 PM	0	19	10	0	7	6	0	0	4	83	1	0	0	0	0	0	130	
4:10 PM	0	20	5	0	12	9	0	0	2	65	0	0	0	0	0	0	113	
4:15 PM	0	5	17	0	10	16	0	0	3	74	1	0	0	0	0	0	126	
4:20 PM	0	11	7	0	7	26	0	0	4	54	1	0	0	0	0	0	110	
4:25 PM	0	13	7	0	6	16	0	0	2	59	2	0	0	0	0	0	105	
4:30 PM	0	11	12	0	10	11	0	0	2	79	5	0	0	0	0	0	130	
4:35 PM	0	18	7	0	8	12	0	0	4	108	3	0	0	0	0	0	160	
4:40 PM	0	12	8	0	4	13	0	0	1	109	2	0	0	0	0	0	149	
4:45 PM	0	10	11	0	3	9	0	0	2	89	2	0	0	0	0	0	126	
4:50 PM	0	11	9	0	5	17	0	0	1	62	1	0	0	0	0	0	106	
4:55 PM	0	14	9	0	7	18	0	0	3	70	0	0	0	0	0	0	121	1496
5:00 PM	0	15	16	0	7	17	0	0	3	113	1	0	0	0	0	0	172	1548
5:05 PM	0	14	25	0	10	12	0	0	2	107	0	0	0	0	0	0	170	1588
5:10 PM	0	16	11	0	10	16	0	0	6	99	2	0	0	0	0	0	160	1635
5:15 PM	0	15	11	0	1	7	0	0	8	98	0	0	0	0	0	0	140	1649
5:20 PM	0	15	12	0	9	16	0	0	4	46	0	0	0	0	0	0	102	1641
5:25 PM	0	14	14	0	6	11	0	0	2	68	3	0	0	0	0	0	118	1654
5:30 PM	0	17	9	0	2	8	0	0	2	67	0	0	0	0	0	0	105	1629
5:35 PM	0	9	10	0	6	15	0	0	3	72	1	0	0	0	0	0	116	1585
5:40 PM	0	6	6	0	8	15	0	0	2	65	1	0	0	0	0	0	103	1539
5:45 PM	0	13	5	0	4	11	0	0	5	47	2	0	0	0	0	0	87	1500
5:50 PM	0	8	5	0	8	11	0	0	2	41	0	0	0	0	0	0	75	1469
5:55 PM	0	12	7	0	7	17	0	0	3	43	3	0	0	0	0	0	92	1440
Peak 15-Min Flowrates	Northbound				Southbound				Eastbound				Westbound				Total	
	Left	Thru	Right	U	Left	Thru	Right	U	Left	Thru	Right	U	Left	Thru	Right	U		
All Vehicles	0	180	208	0	108	180	0	0	44	1276	12	0	0	0	0	0	2008	
Heavy Trucks	0	0	0	0	0	0	0	0	8	24	0	0	0	0	0	0	32	
Pedestrians		4				12				56				44			116	
Bicycles	0	0	0	0	0	0	0	0	0	0	0	0	0	0	0	0	0	
Railroad																		
Stopped Buses																		

Comments: N/A