

LOCATION: Columbia St -- W McLoughlin Blvd
CITY/STATE: Vancouver, WA

QC JOB #: 13418649
DATE: Thu, Jun 11 2015

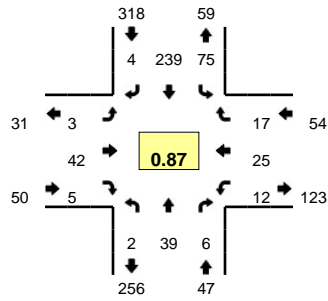

Peak-Hour: 7:00 AM -- 8:00 AM
Peak 15-Min: 7:45 AM -- 8:00 AM

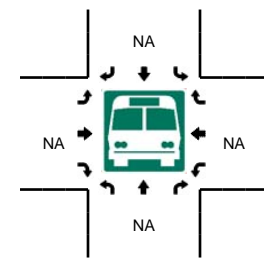
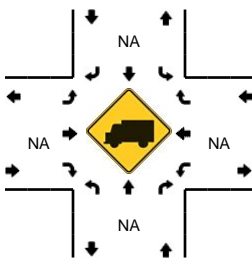
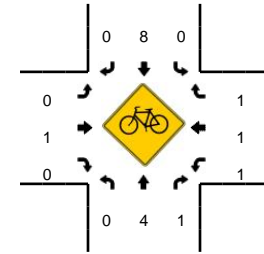
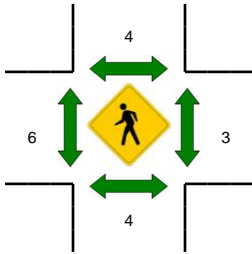
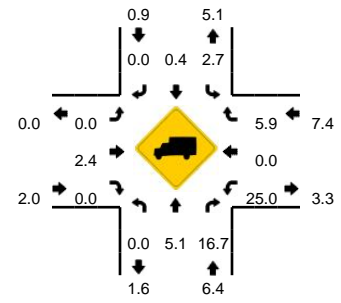

5-Min Count Period Beginning At	Columbia St (Northbound)				Columbia St (Southbound)				W McLoughlin Blvd (Eastbound)				W McLoughlin Blvd (Westbound)				Total	Hourly Totals	
	Left	Thru	Right	U	Left	Thru	Right	U	Left	Thru	Right	U	Left	Thru	Right	U			
7:00 AM	0	2	1	0	3	21	0	0	0	4	1	0	0	2	1	0	0	35	
7:05 AM	0	3	1	0	8	11	0	0	0	0	1	0	0	2	4	1	0	31	
7:10 AM	0	4	0	0	5	13	0	0	0	4	0	0	0	0	2	2	0	30	
7:15 AM	0	1	0	0	7	20	1	0	0	4	0	0	0	1	0	1	0	35	
7:20 AM	0	5	1	0	7	25	1	0	0	3	0	0	0	1	1	2	0	46	
7:25 AM	0	1	0	0	5	22	0	0	1	6	0	0	0	1	1	2	0	39	
7:30 AM	0	3	0	0	6	22	0	0	0	5	2	0	0	3	1	0	0	42	
7:35 AM	0	3	0	0	5	15	1	0	0	6	1	0	0	0	4	1	0	36	
7:40 AM	0	3	1	0	7	23	0	0	2	2	0	0	0	0	1	1	0	40	
7:45 AM	1	4	0	0	12	25	0	0	0	3	0	0	0	1	3	1	0	50	
7:50 AM	1	4	0	0	6	21	1	0	0	3	0	0	0	2	3	2	0	43	
7:55 AM	0	6	2	0	4	21	0	0	0	2	0	0	0	1	3	3	0	42	469
8:00 AM	0	6	0	0	4	12	0	0	0	3	1	0	0	0	1	3	0	30	464
8:05 AM	0	8	0	0	1	11	0	0	0	2	0	0	0	0	1	3	0	26	459
8:10 AM	0	6	1	0	2	12	0	0	1	3	2	0	0	0	3	3	0	33	462
8:15 AM	0	5	3	0	7	10	0	0	3	5	1	0	0	1	1	2	0	38	465
8:20 AM	0	9	1	0	6	8	0	0	0	7	4	0	0	1	1	0	0	37	456
8:25 AM	1	10	0	0	6	6	0	0	5	8	3	0	0	2	2	0	0	43	460
8:30 AM	0	2	1	0	2	18	1	0	0	3	4	0	0	4	3	3	0	41	459
8:35 AM	0	3	4	0	3	9	1	0	1	4	1	0	0	2	1	3	0	32	455
8:40 AM	0	1	2	0	6	11	0	0	2	5	0	0	0	2	1	2	0	32	447
8:45 AM	0	4	2	0	3	11	0	0	0	3	0	0	0	3	1	2	0	29	426
8:50 AM	0	6	2	0	4	15	0	0	0	3	0	0	0	2	3	1	0	36	419
8:55 AM	1	4	1	0	3	12	1	0	0	3	0	0	0	0	1	3	0	29	406
Peak 15-Min Flowrates	Northbound				Southbound				Eastbound				Westbound				Total		
	Left	Thru	Right	U	Left	Thru	Right	U	Left	Thru	Right	U	Left	Thru	Right	U			
All Vehicles	8	56	8	0	88	268	4	0	0	32	0	0	16	36	24	0	540		
Heavy Trucks	0	8	4		4	0	0		0	0	0		4	0	0		20		
Pedestrians		4			16				16				4				40		
Bicycles	0	2	0		0	2	0		0	0	0		0	0	0		4		
Railroad																			
Stopped Buses																			

Comments: N/A