

LOCATION: W 26th Ave -- W Fourth Plain Blvd
CITY/STATE: Vancouver, WA

QC JOB #: 14671711
DATE: Tue, Apr 10 2018

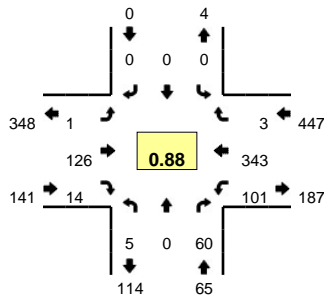

Peak-Hour: 7:05 AM -- 8:05 AM
Peak 15-Min: 7:40 AM -- 7:55 AM

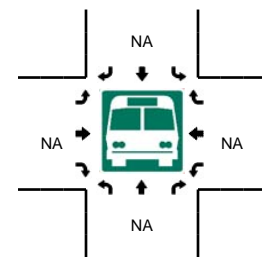
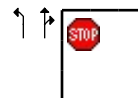
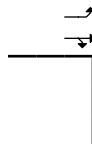
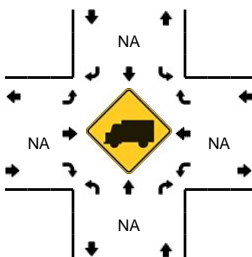
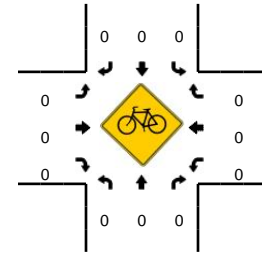
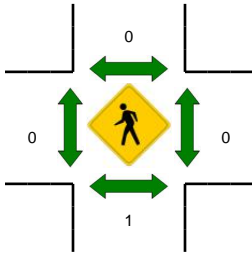
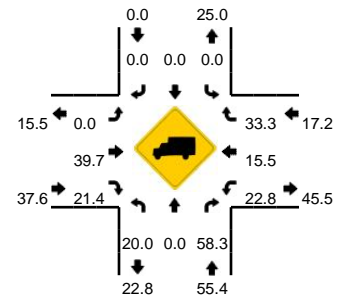

5-Min Count Period Beginning At	W 26th Ave (Northbound)				W 26th Ave (Southbound)				W Fourth Plain Blvd (Eastbound)				W Fourth Plain Blvd (Westbound)				Total	Hourly Totals
	Left	Thru	Right	U	Left	Thru	Right	U	Left	Thru	Right	U	Left	Thru	Right	U		
7:00 AM	1	0	4	0	0	0	0	0	0	5	0	0	9	14	0	0	33	
7:05 AM	0	0	7	0	0	0	0	0	0	15	0	0	12	29	0	0	63	
7:10 AM	0	0	5	0	0	0	0	0	0	15	0	0	10	30	0	0	60	
7:15 AM	1	0	5	0	0	0	0	0	0	13	0	0	4	21	0	0	44	
7:20 AM	0	0	4	0	0	0	0	0	0	9	0	0	12	27	0	0	52	
7:25 AM	0	0	7	0	0	0	0	0	0	9	0	0	12	27	0	0	55	
7:30 AM	0	0	3	0	0	0	0	0	0	9	0	0	10	32	0	0	54	
7:35 AM	1	0	5	0	0	0	0	0	0	6	6	0	7	22	1	0	48	
7:40 AM	2	0	5	0	0	0	0	0	1	6	3	0	13	40	1	0	71	
7:45 AM	0	0	1	0	0	0	0	0	0	10	2	0	7	26	0	1	47	
7:50 AM	0	0	10	0	0	0	0	0	0	10	3	0	7	37	1	0	68	
7:55 AM	1	0	5	0	0	0	0	0	0	14	0	0	4	26	0	0	50	645
8:00 AM	0	0	3	0	0	0	0	0	0	10	0	0	2	26	0	0	41	653
8:05 AM	0	0	1	0	0	0	0	0	0	13	1	0	5	23	0	0	43	633
8:10 AM	0	0	3	0	0	0	0	0	0	11	0	0	3	18	0	0	35	608
8:15 AM	0	0	5	0	0	0	0	0	0	9	1	0	4	22	0	0	41	605
8:20 AM	0	0	3	0	0	0	0	0	1	6	0	0	4	17	1	0	32	585
8:25 AM	3	0	4	0	0	0	1	0	0	11	1	0	1	17	0	0	38	568
8:30 AM	0	0	5	0	0	0	0	0	0	16	0	0	3	25	0	0	49	563
8:35 AM	2	0	2	0	0	0	0	0	0	18	0	0	7	20	0	0	49	564
8:40 AM	2	0	4	0	0	0	0	0	0	9	1	0	3	18	1	0	38	531
8:45 AM	1	0	9	0	0	0	0	0	0	20	1	0	1	15	0	0	47	531
8:50 AM	1	0	1	0	0	0	0	0	1	12	1	0	5	15	0	0	36	499
8:55 AM	1	0	2	0	0	0	2	0	0	18	1	0	5	16	1	0	46	495
Peak 15-Min Flowrates	Northbound				Southbound				Eastbound				Westbound				Total	
	Left	Thru	Right	U	Left	Thru	Right	U	Left	Thru	Right	U	Left	Thru	Right	U		
All Vehicles	8	0	64	0	0	0	0	0	4	104	32	0	108	412	8	4	744	
Heavy Trucks	0	0	24	0	0	0	0	0	0	56	8	0	24	68	0	0	180	
Pedestrians	0	0	0	0	0	0	0	0	0	0	0	0	0	0	0	0	0	
Bicycles	0	0	0	0	0	0	0	0	0	0	0	0	0	0	0	0	0	
Railroad																		
Stopped Buses																		

Comments: