

LOCATION: NE Ward Rd/NE 147th Ave -- NE Fourth Plain Rd
CITY/STATE: Vancouver, WA

QC JOB #: 14655106
DATE: Wed, Mar 21 2018

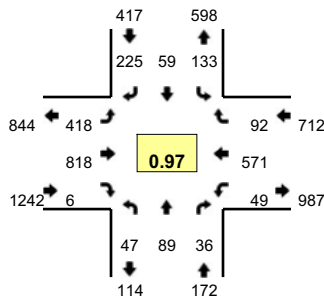

Peak-Hour: 4:15 PM -- 5:15 PM
Peak 15-Min: 4:15 PM -- 4:30 PM

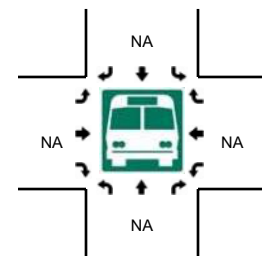
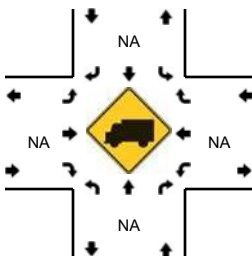
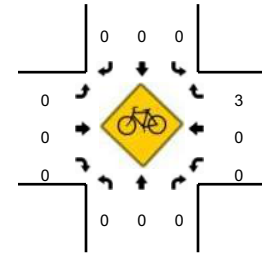
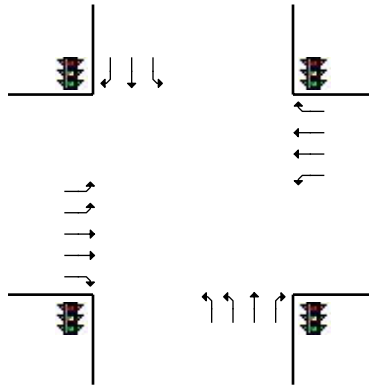
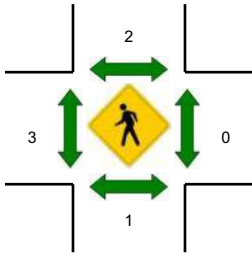
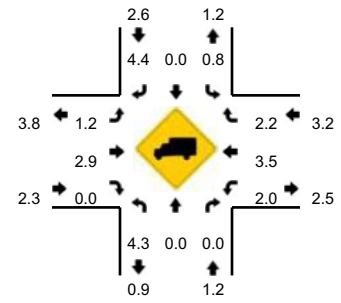

5-Min Count Period Beginning At	NE Ward Rd/NE 147th Ave (Northbound)				NE Ward Rd/NE 147th Ave (Southbound)				NE Fourth Plain Rd (Eastbound)				NE Fourth Plain Rd (Westbound)				Total	Hourly Totals
	Left	Thru	Right	U	Left	Thru	Right	U	Left	Thru	Right	U	Left	Thru	Right	U		
4:00 PM	5	3	8	0	4	6	18	0	25	81	3	0	6	38	8	0	205	
4:05 PM	6	5	2	0	9	3	19	0	24	65	1	0	5	39	7	0	185	
4:10 PM	4	12	4	0	10	6	16	0	18	64	1	0	4	31	14	0	184	
4:15 PM	5	7	2	0	12	10	19	0	29	82	1	0	3	66	13	0	249	
4:20 PM	3	10	0	0	9	7	20	0	36	59	0	0	5	45	8	0	202	
4:25 PM	4	9	4	0	15	4	12	0	20	60	1	0	5	60	12	0	206	
4:30 PM	4	4	4	0	13	3	24	0	33	71	0	0	4	33	6	0	199	
4:35 PM	6	9	2	0	11	1	15	0	32	73	0	0	2	49	5	0	205	
4:40 PM	5	9	4	0	7	4	19	0	43	73	1	0	3	57	3	0	228	
4:45 PM	6	9	4	0	16	5	16	0	32	50	1	0	5	46	5	0	195	
4:50 PM	4	1	5	0	17	4	19	0	34	72	1	0	2	44	9	0	212	
4:55 PM	2	5	5	0	6	6	19	0	43	67	1	0	5	51	6	0	216	2486
5:00 PM	1	9	3	0	5	5	14	0	43	70	0	1	8	31	6	0	196	2477
5:05 PM	3	9	1	0	11	4	23	0	37	60	0	0	4	31	6	0	189	2481
5:10 PM	4	8	2	0	11	6	25	0	35	81	0	0	3	58	13	0	246	2543
5:15 PM	2	11	3	0	6	8	18	0	25	72	2	0	5	48	11	0	211	2505
5:20 PM	3	8	1	0	13	5	12	1	28	63	1	0	5	33	14	0	187	2490
5:25 PM	1	6	1	0	8	8	18	0	32	78	0	0	3	49	9	0	213	2497
5:30 PM	4	7	2	0	3	5	10	0	36	80	1	0	3	50	7	0	208	2506
5:35 PM	1	6	3	0	16	5	19	0	23	73	0	0	3	50	5	0	204	2505
5:40 PM	2	7	1	0	20	11	19	0	27	58	1	0	2	43	8	0	199	2476
5:45 PM	4	8	4	0	12	9	18	0	21	61	1	1	2	46	4	0	191	2472
5:50 PM	1	9	4	0	12	4	12	0	44	80	1	0	5	41	13	0	226	2486
5:55 PM	3	9	4	0	7	5	17	0	38	64	1	0	11	39	14	0	212	2482
Peak 15-Min Flowrates	Northbound				Southbound				Eastbound				Westbound				Total	
	Left	Thru	Right	U	Left	Thru	Right	U	Left	Thru	Right	U	Left	Thru	Right	U		
All Vehicles	48	104	24	0	144	84	204	0	340	804	8	0	52	684	132	0	2628	
Heavy Trucks	4	0	0		4	0	8		0	40	0		0	16	4		76	
Pedestrians		4				8				4				0			16	
Bicycles	0	0	0		0	0	0		0	0	0		0	0	0		0	
Railroad																		
Stopped Buses																		

Comments: