

LOCATION: NE 162nd Ave -- NE Fourth Plain Rd
CITY/STATE: Vancouver, WA

QC JOB #: 14655111
DATE: Wed, Mar 21 2018

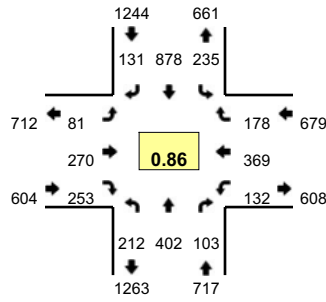

Peak-Hour: 7:20 AM -- 8:20 AM
Peak 15-Min: 7:40 AM -- 7:55 AM

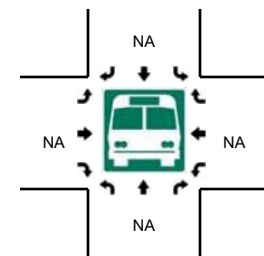
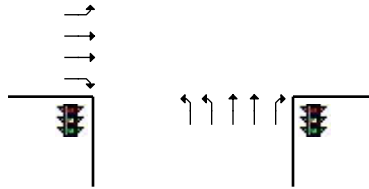
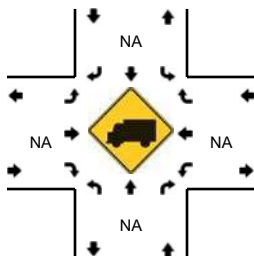
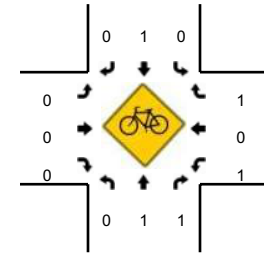
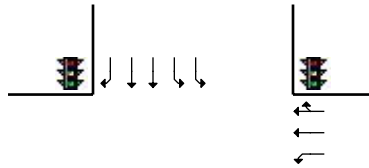
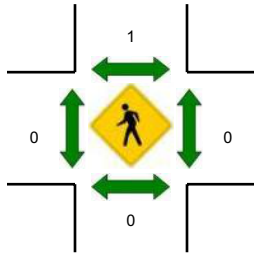
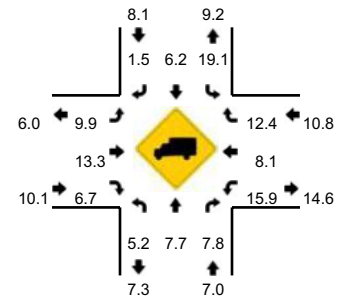

5-Min Count Period Beginning At	NE 162nd Ave (Northbound)				NE 162nd Ave (Southbound)				NE Fourth Plain Rd (Eastbound)				NE Fourth Plain Rd (Westbound)				Total	Hourly Totals
	Left	Thru	Right	U	Left	Thru	Right	U	Left	Thru	Right	U	Left	Thru	Right	U		
7:00 AM	13	18	8	0	21	44	9	0	6	15	14	0	11	27	13	0	199	
7:05 AM	7	35	5	0	7	60	11	0	1	17	15	0	5	22	13	0	198	
7:10 AM	9	31	6	0	8	67	10	0	9	15	17	0	7	23	7	0	209	
7:15 AM	11	37	4	0	18	73	14	0	6	5	20	0	4	17	11	0	220	
7:20 AM	17	41	2	0	12	78	9	0	1	18	25	0	9	25	8	0	245	
7:25 AM	21	34	11	0	12	53	8	0	5	23	25	0	6	30	11	0	239	
7:30 AM	6	22	9	0	14	64	12	0	11	30	17	0	5	38	14	0	242	
7:35 AM	19	41	14	0	26	98	8	0	7	12	22	0	13	26	10	0	296	
7:40 AM	12	46	11	0	38	92	12	0	3	39	15	0	4	32	22	0	326	
7:45 AM	28	27	12	0	25	63	9	0	15	37	34	0	17	26	11	0	304	
7:50 AM	12	32	10	0	20	79	20	0	7	37	27	0	20	34	14	0	312	
7:55 AM	17	43	11	0	26	94	11	0	12	11	14	0	15	35	22	0	311	3101
8:00 AM	14	24	7	0	23	60	10	0	7	21	23	0	12	40	27	0	268	3170
8:05 AM	21	31	4	0	14	73	15	0	4	16	19	0	4	22	14	0	237	3209
8:10 AM	16	21	5	0	10	58	8	0	5	14	17	0	21	39	18	0	232	3232
8:15 AM	29	40	7	0	15	66	9	0	4	12	15	0	6	22	7	0	232	3244
8:20 AM	19	28	7	0	13	64	14	0	9	11	19	0	6	26	9	0	225	3224
8:25 AM	8	22	4	0	4	63	8	0	10	23	14	0	8	31	13	0	208	3193
8:30 AM	18	35	11	0	11	50	12	0	6	19	17	0	6	13	6	0	204	3155
8:35 AM	7	23	6	0	13	71	16	0	10	14	26	0	6	23	10	0	225	3084
8:40 AM	22	28	8	0	8	33	10	0	7	27	16	0	8	31	5	0	203	2961
8:45 AM	17	31	6	0	10	52	5	0	10	20	18	0	16	13	10	0	208	2865
8:50 AM	18	29	8	0	9	80	10	0	9	17	19	0	12	19	7	0	237	2790
8:55 AM	14	14	9	0	15	46	11	0	8	15	19	0	6	23	6	0	186	2665
Peak 15-Min Flowrates	Northbound				Southbound				Eastbound				Westbound				Total	
	Left	Thru	Right	U	Left	Thru	Right	U	Left	Thru	Right	U	Left	Thru	Right	U		
All Vehicles	208	420	132	0	332	936	164	0	100	452	304	0	164	368	188	0	3768	
Heavy Trucks	8	24	8		48	44	0		12	20	4		24	52	24		268	
Pedestrians		0				0				0				0				0
Bicycles		0	1			0	0			0	0			0	1			2
Railroad																		
Stopped Buses																		

Comments: