

INTERSECTION: NE 58th Ave--/NE 63rd--
 PROJECT ID#: 2040323
 QC JOB #: 10063501

START TIME: 7:00 AM
 END TIME: 9:00 AM
 DATE: 10/27/2004



QUALITY COUNTS
 16285 SW 85th Avenue, Ste. 105
 Tigard, OR 97224
 Phone: 503-620-4242
 Fax: 503 620-4545
 email: jrw@qualitycounts.net
 www.qualitycounts.net

PEAK HOUR TURNING MOVEMENTS

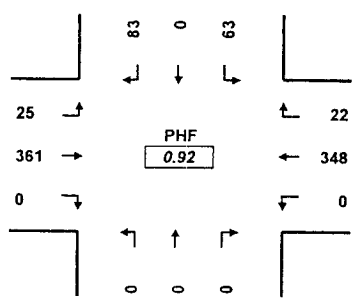

PEAK HOUR LINK VOLUMES

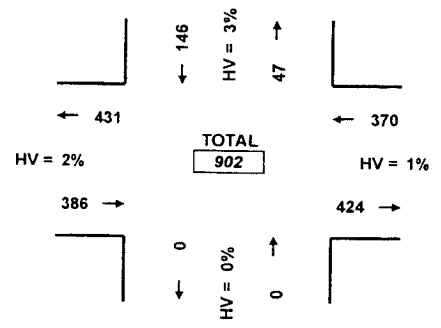

PEAK HOUR: 7:30 AM TO 8:30 AM

PEAK 15 MINUTES: 7:45 AM TO 8:00 AM

PEAK HOUR PED CROSSING VOLUMES

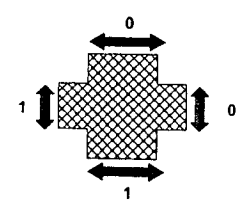

5-MINUTE COUNT PERIOD BEGINNING AT	NE 58th Ave-- (Southbound)			NE 63rd-- (Westbound)			58th-- (Northbound)			63rd-- (Eastbound)			Crosswalk Usage (Peds By Approach)				TOTAL	
	Right	Thru	Left	Right	Thru	Left	Right	Thru	Left	Right	Thru	Left	North	East	South	West	Veh	Peds
7:00 AM	8	0	2	1	20	0	0	0	0	17	1	0	0	0	0	0	49	0
7:05 AM	12	0	2	2	24	0	0	0	0	18	2	1	0	0	0	0	60	1
7:10 AM	6	0	7	0	21	0	0	0	0	13	2	0	0	0	0	0	49	0
7:15 AM	5	0	5	2	29	0	0	0	0	29	1	0	0	0	0	0	71	0
7:20 AM	9	0	3	0	36	0	0	0	0	20	0	0	0	0	0	0	68	0
7:25 AM	8	0	2	2	21	0	0	0	0	41	0	0	0	0	0	0	74	0
7:30 AM	0	0	5	1	31	0	0	0	0	27	2	0	0	0	0	0	66	0
7:35 AM	11	0	4	6	24	0	0	0	0	40	1	0	0	0	0	0	86	0
7:40 AM	7	0	13	1	28	0	0	0	0	38	2	0	0	1	0	0	89	1
7:45 AM	8	0	3	0	30	0	0	0	0	39	3	0	0	0	0	0	83	0
7:50 AM	11	0	3	1	46	0	0	0	0	34	3	0	0	0	0	0	98	0
7:55 AM	2	0	7	2	19	0	0	0	0	32	1	0	0	0	0	0	63	0
8:00 AM	7	0	3	0	16	0	0	0	0	23	3	0	0	0	0	0	52	0
8:05 AM	10	0	6	2	33	0	0	0	0	18	5	0	0	0	0	0	74	0
8:10 AM	6	0	4	4	30	0	0	0	0	30	0	0	0	0	1	0	74	1
8:15 AM	7	0	5	1	25	0	0	0	0	38	3	0	0	0	0	0	79	0
8:20 AM	8	0	7	4	38	0	0	0	0	16	2	0	0	0	0	0	75	0
8:25 AM	6	0	3	0	28	0	0	0	0	26	0	0	0	0	0	0	63	0
8:30 AM	4	0	4	1	24	0	0	0	0	31	1	0	0	0	0	0	65	0
8:35 AM	5	0	2	2	17	0	0	0	0	25	4	0	0	0	0	0	55	0
8:40 AM	5	0	4	5	24	0	0	0	0	33	0	1	0	0	0	0	71	1
8:45 AM	3	0	0	1	24	0	0	0	0	25	6	0	0	0	0	0	59	0
8:50 AM	7	0	2	0	21	0	0	0	0	24	4	0	0	0	0	0	58	0
8:55 AM	4	0	3	2	19	0	0	0	0	28	1	0	0	0	0	0	57	0
HOURLY TOTALS	Southbound			Westbound			Northbound			Eastbound			Pedestrians By Approach				TOTAL	
	Right	Thru	Left	Right	Thru	Left	Right	Thru	Left	Right	Thru	Left	North	East	South	West	Veh	Peds
7:00 AM	87	0	56	18	329	0	0	0	0	348	18	1	0	1	0	0	856	2
7:15 AM	84	0	58	21	343	0	0	0	0	371	21	0	0	1	1	1	898	2
7:30 AM	83	0	63	22	348	0	0	0	0	361	25	0	0	1	1	1	902	2
7:45 AM	79	0	51	22	330	0	0	0	0	345	25	1	0	0	0	1	852	2
8:00 AM	72	0	43	22	299	0	0	0	0	317	29	1	0	0	0	1	782	2