



Interval 60 min. 15 min.

Count(volume) Speed

Binned(CL/SP) Raw

Lane No 1 2

Direction Channel 1 _____

Direction Channel 2 _____

Data Hog # 7064

Counter No. 3472-13 Count ID SP#05-006

SR 005 RRT/RRQ Fl Temp MP 16.80

Leg E Direction WB OSID B

Station Description ON La Center Rd E/O Paradise Park Rd

Date	Day	Time	Comments
3-21-05	2	12:06	Manual (1) 5 (2) _____ Set Ok Counter (1) 5 (2) _____ CS/MD 6.8V
3-22-05	3	7:34	Manual (1) 35 (2) _____ Check Ok Counter (1) 35 (2) _____ CS/MD 6.5V
3-23-05	4	10:11	Manual (1) 20 (2) _____ Check Ok Counter (1) 20 (2) _____ CS/MD 6.9V
3-24-05	5	7:52	Manual (1) 30 (2) _____ Check Ok Counter (1) 30 (2) _____ CS/MD 6.5V
3-25-05	6	7:55	Manual (1) 1 (2) _____ Pick Up Counter (1) 1 (2) _____ CS/MD 6.4V

Sketch

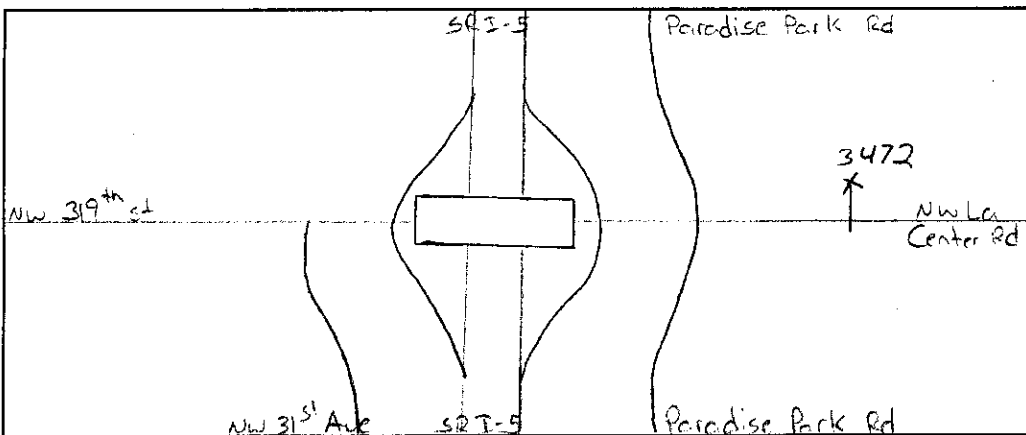

C. Shelton/M. Dietz
Field Person



Interval 60 min. 15 min.

Count(volume) Speed

Binned(CL/SP) Raw

Lane No 1 2

Direction Channel 1 _____

Direction Channel 2 _____

Data Hog # 7064

Counter No. 2917-13 Count ID SP#05-006

SR 005 RRT/RRQ Fl Temp MP 16.80

Leg E Direction EB OSID (B)

Station Description _ ON La Center Rd E/O Paradise Park Rd

Date	Day	Time	Comments
3-21-05	2	12:04	Manual (1) <u>2</u> (2) Set Ok Counter (1) <u>2</u> (2) CS/MD 6.7V
3-22-05	3	7:33	Manual (1) <u>25</u> (2) Check Ok Counter (1) <u>25</u> (2) CS/MD 6.4V
3-23-05	4	10:10	Manual (1) <u>15</u> (2) Check Ok Counter (1) <u>15</u> (2) CS/MD 6.4V
3-24-05	5	7:51	Manual (1) <u>23</u> (2) Check Ok Counter (1) <u>23</u> (2) CS/MD 6.4V
3-25-05	6	7:48	Manual (1) <u>1</u> (2) Pick Up Counter (1) <u>1</u> (2) CS/MD 6.3V

Sketch

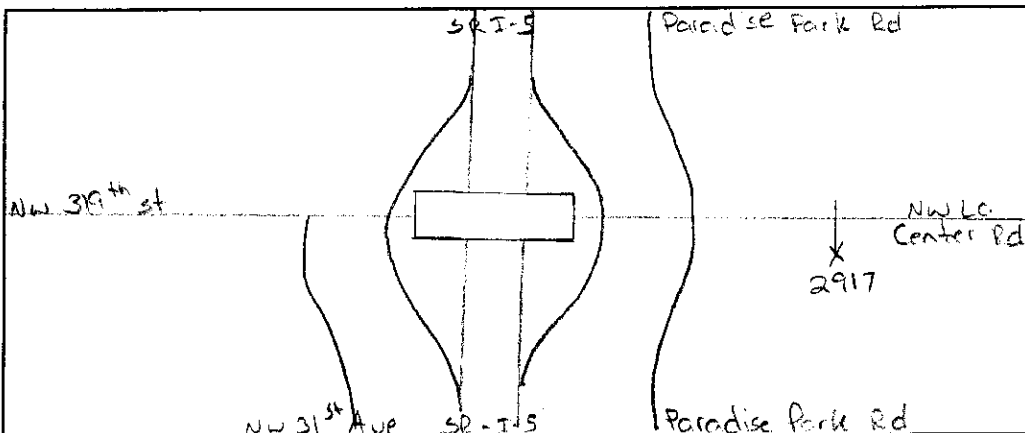

C. Shelton / M. Dietz
Field Person

SR 005 MP 016.80 OFF SYSTEM ID. B LEG E DIRECTION OF TRAFFIC WESTBOUND LANE ALL OF

COUNT IDENTIFIER 05-006 COUNTER NUMBER 003472 DESCRIPTION: ON LA CENTER RD E/O PARADISE PARK RD

03/21/05 MONDAY		AM HOURS												PM HOURS												DAILY TOTAL	
TIME	COUNT	1	2	3	4	5	6	7	8	9	10	11	12	1	2	3	4	5	6	7	8	9	10	11	12	TOTAL	TOTAL
00-15	12	1	2	3	4	5	6	7	8	9	10	11	12	1	2	3	4	5	6	7	8	9	10	11	12	206	255
15-30	1	2	3	4	5	6	7	8	9	10	11	12	1	2	3	4	5	6	7	8	9	10	11	12	226	287	
30-45	1	2	3	4	5	6	7	8	9	10	11	12	1	2	3	4	5	6	7	8	9	10	11	12	226	287	
45-00	1	2	3	4	5	6	7	8	9	10	11	12	1	2	3	4	5	6	7	8	9	10	11	12	280	218	
HOUR																											
TOT																									206	255	

AM PEAK HOUR 0000 TO 0000 VOLUME 0
PM PEAK HOUR 0400 TO 0500 VOLUME 329

03/22/05 TUESDAY		AM HOURS												PM HOURS												DAILY TOTAL	
TIME	COUNT	1	2	3	4	5	6	7	8	9	10	11	12	1	2	3	4	5	6	7	8	9	10	11	12	TOTAL	TOTAL
00-15	12	1	2	3	4	5	6	7	8	9	10	11	12	1	2	3	4	5	6	7	8	9	10	11	12	420	303
15-30	1	2	3	4	5	6	7	8	9	10	11	12	1	2	3	4	5	6	7	8	9	10	11	12	226	287	
30-45	1	2	3	4	5	6	7	8	9	10	11	12	1	2	3	4	5	6	7	8	9	10	11	12	226	287	
45-00	1	2	3	4	5	6	7	8	9	10	11	12	1	2	3	4	5	6	7	8	9	10	11	12	299	295	
HOUR																											
TOT																									420	303	

AM PEAK HOUR 0630 TO 0730 VOLUME 613
PM PEAK HOUR 0330 TO 0430 VOLUME 312

03/23/05 WEDNESDAY		AM HOURS												PM HOURS												DAILY TOTAL	
TIME	COUNT	1	2	3	4	5	6	7	8	9	10	11	12	1	2	3	4	5	6	7	8	9	10	11	12	TOTAL	TOTAL
00-15	12	1	2	3	4	5	6	7	8	9	10	11	12	1	2	3	4	5	6	7	8	9	10	11	12	448	287
15-30	1	2	3	4	5	6	7	8	9	10	11	12	1	2	3	4	5	6	7	8	9	10	11	12	266	309	
30-45	1	2	3	4	5	6	7	8	9	10	11	12	1	2	3	4	5	6	7	8	9	10	11	12	266	309	
45-00	1	2	3	4	5	6	7	8	9	10	11	12	1	2	3	4	5	6	7	8	9	10	11	12	292	295	
HOUR																											
TOT																									448	287	

AM PEAK HOUR 0645 TO 0745 VOLUME 605
PM PEAK HOUR 0415 TO 0515 VOLUME 309

03/23/05 WEDNESDAY		AM HOURS												PM HOURS												DAILY TOTAL	
TIME	COUNT	1	2	3	4	5	6	7	8	9	10	11	12	1	2	3	4	5	6	7	8	9	10	11	12	TOTAL	TOTAL
00-15	12	1	2	3	4	5	6	7	8	9	10	11	12	1	2	3	4	5	6	7	8	9	10	11	12	448	287
15-30	1	2	3	4	5	6	7	8	9	10	11	12	1	2	3	4	5	6	7	8	9	10	11	12	266	309	
30-45	1	2	3	4	5	6	7	8	9	10	11	12	1	2	3	4	5	6	7	8	9	10	11	12	266	309	
45-00	1	2	3	4	5	6	7	8	9	10	11	12	1	2	3	4	5	6	7	8	9	10	11	12	292	295	
HOUR																											
TOT																									448	287	

AM PEAK HOUR 0645 TO 0745 VOLUME 605
PM PEAK HOUR 0415 TO 0515 VOLUME 309

TRIP SYSTEM
15 MINUTE TRAFFIC COUNT SUMMARY

SR 005 MP 016.80 OFF SYSTEM ID. B LEG E DIRECTION OF TRAFFIC WESTBOUND LANE ALL OF

COUNT IDENTIFIER 05-006 COUNTER NUMBER 003472 DESCRIPTION: ON LA CENTER RD E/O PARADISE PARK RD

03/24/05	THURSDAY												DAILY TOTAL											
	AM HOURS						PM HOURS																	
12	1	2	3	4	5	6	7	8	9	10	11	12	1	2	3	4	5	6	7	8	9	10	11	12
12	1	2	3	4	5	6	7	8	9	10	11	12	1	2	3	4	5	6	7	8	9	10	11	12
22	20	12	18	36	32	124	150	105	65	60	70	52	68	63	99	94	84	68	47	46	33	30	30	35
15-30	15	19	16	13	44	64	96	136	86	72	70	65	78	62	88	78	71	62	45	43	28	39	27	21
30-45	23	9	11	21	35	65	133	100	81	79	71	58	77	70	96	83	91	60	54	33	27	26	21	
45-00	16	21	19	24	37	87	139	78	81	67	53	53	55	80	62	75	65	46	21	30	35	20	14	
TOT	76	69	58	76	152	248	492	580	419	313	278	264	228	278	275	345	330	311	236	167	152	123	115	97
									AM PEAK HOUR 0645 TO 0745 VOLUME							583					AM TOTAL		3025	
									PM PEAK HOUR 0245 TO 0345 VOLUME							363					PM TOTAL		2657	

03/25/05	FRIDAY												DAILY TOTAL											
	AM HOURS						PM HOURS																	
12	1	2	3	4	5	6	7	8	9	10	11	12	1	2	3	4	5	6	7	8	9	10	11	12
12	1	2	3	4	5	6	7	8	9	10	11	12	1	2	3	4	5	6	7	8	9	10	11	12
26	25	18	21	35	38	94	117																	
15-30	13	11	17	16	38	39	100	128																
30-45	24	25	17	19	42	58	116	139																
45-00	18	11	15	23	28	85	125																	
TOT	81	72	67	79	141	220	435	384																
									AM PEAK HOUR 0645 TO 0745 VOLUME							509						AM TOTAL		1479
									PM PEAK HOUR 0000 TO 0000 VOLUME							0						PM TOTAL		0

03/21/05 THRU 03/25/05
TOTAL HOURS FOR COUNT 90

3 DAYS
AVG WEEKDAY VOL 5537 X SEASONAL ADJ. FACTOR 1.0000 = 5537 X AXLE CORR FACTOR 1.0000 = ESTIMATED AVG DAILY TRAFFIC 5537

SR 005 MP 016.80 OFF SYSTEM ID. B LEG E DIRECTION OF TRAFFIC EASTBOUND LANE ALL OF

COUNT IDENTIFIER 05-006 COUNTER NUMBER 002917 DESCRIPTION: ON LA CENTER RD E/O PARADISE PARK RD

03/21/05	MONDAY												DAILY												
	AM HOURS																								
12	1	2	3	4	5	6	7	8	9	10	11	12													
12	1	2	3	4	5	6	7	8	9	10	11	12	1	2	3	4	5	6	7	8	9	10	11	12	TOTAL
00-15													60	67	88	104	130	129	77	51	51	38	31		
15-30													53	66	84	100	144	171	119	66	70	52	28	26	
30-45													54	67	73	116	149	177	115	77	53	56	38	22	
45-00													73	72	106	128	148	151	103	64	61	44	29	15	
HOUR																									
TOT													180	265	330	432	545	629	466	284	235	203	133	94	3796

AM PEAK HOUR 0000 TO 0000 VOLUME 0
 PM PEAK HOUR 0500 TO 0600 VOLUME 629
 AM TOTAL 0
 PM TOTAL 3796

03/22/05	TUESDAY												DAILY														
	AM HOURS																										
12	1	2	3	4	5	6	7	8	9	10	11	12															
12	1	2	3	4	5	6	7	8	9	10	11	12	1	2	3	4	5	6	7	8	9	10	11	12	TOTAL		
00-15													35	45	35	52	56	59	61	71	102	125	143	78	43	41	11
15-30													34	42	42	38	69	59	70	86	115	128	167	121	68	46	25
30-45													33	33	53	35	58	62	79	92	133	124	171	126	66	55	18
45-00													42	45	60	69	85	66	95	119	149	167	92	57	48	52	23
HOUR																											
TOT													154	175	185	252	265	276	344	469	526	648	482	279	241	200	140

AM PEAK HOUR 1100 TO 1200 VOLUME 252
 PM PEAK HOUR 0515 TO 0615 VOLUME 648
 AM TOTAL 1294
 PM TOTAL 3947

03/23/05	WEDNESDAY												DAILY														
	AM HOURS																										
12	1	2	3	4	5	6	7	8	9	10	11	12															
12	1	2	3	4	5	6	7	8	9	10	11	12	1	2	3	4	5	6	7	8	9	10	11	12	TOTAL		
00-15													44	37	51	72	53	68	84	86	107	140	102	90	63	67	46
15-30													41	36	52	63	57	69	82	96	131	168	128	74	56	64	22
30-45													35	50	54	67	65	75	90	121	135	185	113	86	45	61	40
45-00													42	46	56	62	80	82	89	140	135	161	96	77	57	54	30
HOUR																											
TOT													162	169	213	264	255	294	345	443	508	654	439	327	221	246	138

AM PEAK HOUR 1100 TO 1200 VOLUME 264
 PM PEAK HOUR 0500 TO 0600 VOLUME 654
 AM TOTAL 1346
 PM TOTAL 3970

5316

TRIP SYSTEM
15 MINUTE TRAFFIC COUNT SUMMARY

SR 005 MP 016.80 OFF SYSTEM ID. B LEG E DIRECTION OF TRAFFIC EASTBOUND LANE ALL OF

COUNT IDENTIFIER 05-006 COUNTER NUMBER 002917 DESCRIPTION: ON LA CENTER RD E/O PARADISE PARK RD

03/24/05 THURSDAY		AM HOURS											PM HOURS											DAILY TOTAL		
TIME	COUNT	1	2	3	4	5	6	7	8	9	10	11	12	1	2	3	4	5	6	7	8	9	10	11	12	
00-15	12	1	2	3	4	5	6	7	8	9	10	11	12	1	2	3	4	5	6	7	8	9	10	11	12	1382
15-30	1	2	3	4	5	6	7	8	9	10	11	12	1	2	3	4	5	6	7	8	9	10	11	12	4121	
30-45	24	12	8	7	9	10	10	43	39	32	54	55	68	66	83	95	125	143	127	83	78	61	58	29		
45-00	13	13	6	6	3	7	20	52	41	47	60	53	72	67	102	104	117	181	124	82	71	66	40	26		
TOT	79	35	26	22	21	27	105	237	167	184	224	255	259	305	383	458	514	609	456	328	263	257	171	118		
									AM PEAK HOUR 1100 TO 1200 VOLUME 255															AM TOTAL 1382		
									PM PEAK HOUR 0445 TO 0545 VOLUME 616																PM TOTAL 4121	

03/25/05 FRIDAY		AM HOURS											PM HOURS											DAILY TOTAL		
TIME	COUNT	1	2	3	4	5	6	7	8	9	10	11	12	1	2	3	4	5	6	7	8	9	10	11	12	
00-15	12	1	2	3	4	5	6	7	8	9	10	11	12	1	2	3	4	5	6	7	8	9	10	11	12	498
15-30	1	2	3	4	5	6	7	8	9	10	11	12	1	2	3	4	5	6	7	8	9	10	11	12	0	
30-45	27	8	8	8	8	5	5	12	38																	
45-00	24	13	8	7	5	8	20	71																		
TOT	82	36	27	26	23	25	109	170																		
									AM PEAK HOUR 0645 TO 0745 VOLUME 210																AM TOTAL 498	
									PM PEAK HOUR 0000 TO 0000 VOLUME 0																	PM TOTAL 0

03/21/05 THRU 03/25/05
TOTAL HOURS FOR COUNT 90

3 DAYS
AVG WEEKDAY VOL 5353 X SEASONAL ADJ. FACTOR 1.0000 = 5353 X AXLE CORR FACTOR 1.0000 = ESTIMATED AVG DAILY TRAFFIC 5353

SR 005 MP 016.80 OFF SYSTEM ID. B LEG E DIRECTION OF TRAFFIC BOTH WAYS LANE ALL OF

COUNT IDENTIFIER 05-006 COUNTER NUMBER 002917 DESCRIPTION: ON LA CENTER RD E/O PARADISE PARK RD

03/21/05	MONDAY												DAILY																			
	AM HOURS																															
00-15	12	1	2	3	4	5	6	7	8	9	10	11	12	TOTAL																		
12	1	2	3	4	5	6	7	8	9	10	11	12	1	2	3	4	5	6	7	8	9	10	11	12	TOTAL							
135	126	134	170	202	208	186	138	89	85	79	52	108	129	116	200	232	165	114	86	80	58	47	45-00	47	29							
143	140	170	185	231	214	145	106	87	72	47	29	386	520	556	719	874	909	684	468	362	314	231	176	6199								
TOT													AM TOTAL	0	PM TOTAL	6199	AM TOTAL	0	PM TOTAL	6199	AM TOTAL	4363	PM TOTAL	6485	AM TOTAL	4363	PM TOTAL	6485	AM TOTAL	4363	PM TOTAL	6485

03/22/05	TUESDAY												DAILY																			
	AM HOURS																															
00-15	12	1	2	3	4	5	6	7	8	9	10	11	12	TOTAL																		
12	1	2	3	4	5	6	7	8	9	10	11	12	1	2	3	4	5	6	7	8	9	10	11	12	TOTAL							
138	98	80	102	166	300	618	800	574	478	405	464	504	495	576	768	821	948	714	486	381	324	252	147	10639								
TOT													AM PEAK HOUR 0700 TO 0800 VOLUME	800	PM PEAK HOUR 0500 TO 0600 VOLUME	948	AM TOTAL	4223	PM TOTAL	6416	AM TOTAL	4223	PM TOTAL	6416	AM TOTAL	4223	PM TOTAL	6416	AM TOTAL	4223	PM TOTAL	6416

03/23/05	WEDNESDAY												DAILY																			
	AM HOURS																															
00-15	12	1	2	3	4	5	6	7	8	9	10	11	12	TOTAL																		
12	1	2	3	4	5	6	7	8	9	10	11	12	1	2	3	4	5	6	7	8	9	10	11	12	TOTAL							
163	117	81	93	172	286	614	777	610	456	484	510	483	552	611	752	800	949	681	519	351	362	243	182	10848								
TOT													AM PEAK HOUR 0645 TO 0745 VOLUME	790	PM PEAK HOUR 0500 TO 0600 VOLUME	949	AM TOTAL	4363	PM TOTAL	6485	AM TOTAL	4363	PM TOTAL	6485	AM TOTAL	4363	PM TOTAL	6485	AM TOTAL	4363	PM TOTAL	6485

SR 005 MP 016.80 OFF SYSTEM ID. B LEG E DIRECTION OF TRAFFIC BOTH WAYS LANE ALL OF
 COUNT IDENTIFIER 05-006 COUNTER NUMBER 002917 DESCRIPTION: ON LA CENTER RD E/O PARADISE PARK RD

03/24/05	THURSDAY												DAILY TOTAL												
	AM HOURS						PM HOURS																		
	1	2	3	4	5	6	7	8	9	10	11	12	1	2	3	4	5	6	7	8	9	10	11	12	
00-15	46	32	20	25	45	36	134	193	144	97	114	125	120	134	146	194	219	227	195	130	124	94	88	64	
15-30	28	32	22	19	47	71	116	212	177	133	132	123	137	145	164	192	195	252	186	127	114	94	79	53	
30-45	47	14	17	29	40	69	161	186	149	137	137	156	121	152	169	226	205	233	161	149	86	100	67	42	
45-00	34	26	25	25	41	99	186	226	116	130	119	115	109	152	179	191	225	208	150	89	91	92	52	56	
TOT	155	104	84	98	173	275	597	817	586	497	502	519	487	583	658	803	844	920	692	495	415	380	286	215	11185
									AM PEAK HOUR 0700 TO 0800 VOLUME 817							PM PEAK HOUR 0445 TO 0545 VOLUME 937						AM TOTAL 4407		PM TOTAL 6778	

03/25/05	FRIDAY												DAILY TOTAL												
	AM HOURS						PM HOURS																		
	1	2	3	4	5	6	7	8	9	10	11	12	1	2	3	4	5	6	7	8	9	10	11	12	
00-15	53	33	26	29	38	43	106	155																	
15-30	37	24	25	23	43	47	120	199																	
30-45	40	33	22	24	47	62	153	200																	
45-00	33	18	21	29	36	93	165																		
TOT	163	108	94	105	164	245	544	554																	1977
									AM PEAK HOUR 0645 TO 0745 VOLUME 719							PM PEAK HOUR 0000 TO 0000 VOLUME 0						AM TOTAL 1977		PM TOTAL 0	

03/21/05 THRU 03/25/05 TOTAL HOURS FOR COUNT 90
 3 DAYS
 AVG WEEKDAY VOL 10891 X SEASONAL ADJ. FACTOR 1.0000 = 10891 X AXLE CORR FACTOR 1.0000 = ESTIMATED AVG DAILY TRAFFIC 10891
 PEAK HOUR PERCENTAGES: K = 8.71 D = 68.91
 PEAK HOUR LOCATION : VOLUME = 949 DATE: 03/23/05 TIME: 05:00 PM



Interval 60 min. 15 min.

Count(volume) Speed

Binned(CL/SP) Raw

Lane No 1 2

Direction Channel 1 _____

Direction Channel 2 _____

Data Hog # 7064

Counter No. 6484-13 Count ID SP#05-006

SR 005 RRT/RRQ -F1-TEMP MP 16.80

Leg S Direction SB OSID B

Station Description ON Paradise Park Rd S/O La Center Rd

Date	Day	Time	Comments
3-21-05	2	11:57	Manual (1) <u>1</u> (2) Set Ok Counter (1) <u>1</u> (2) CS/MD 6.6V
3-22-05	3	7:26	Manual (1) <u>2</u> (2) Check Ok Counter (1) <u>2</u> (2) CS/MD 6.4V
3-23-05	4	10:27	Manual (1) <u>1</u> (2) Check Ok Counter (1) <u>1</u> (2) CS/MD 6.4V
3-24-05	5	7:44	Manual (1) <u>2</u> (2) Check Ok Counter (1) <u>2</u> (2) CS/MD 6.4V
3-25-05	6	7:44	Manual (1) (2) Pick Up Counter (1) (2) CS/MD 6.4V

Sketch

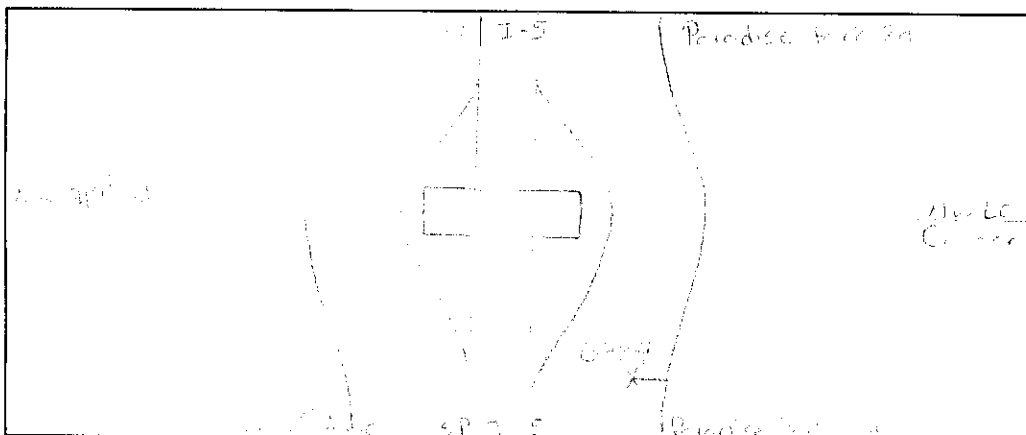

Carroll
Field Person

Interval 60 min. 15 min.

Count(volume) Speed

Binned(CL/SP) Raw

Lane No 1 2

Direction Channel 1 _____

Direction Channel 2 _____

Data Hog # 7064

Counter No. 3448-13 Count ID SP#05-006

SR 005 RRT/RRQ F1-TEMP MP 16.80

Leg S Direction NB OSID B

Station Description ON Paradise Park Rd S/O La Center Rd

Date	Day	Time	Comments
3-21-05	2	11:52	Manual (1) <u>1</u> (2) _____ Set Ok Counter (1) <u>1</u> (2) _____ CS/MD 6.7V
3-22-05	3	7:25	Manual (1) <u>2</u> (2) _____ Check Ok Counter (1) <u>2</u> (2) _____ CS/MD 6.5V
3-23-05	4	10:26	Manual (1) <u>1</u> (2) _____ Check Ok Counter (1) <u>1SV</u> (2) _____ CS/MD 6.6V
3-24-05	5	7:43	Manual (1) <u>2</u> (2) _____ Check Ok Counter (1) <u>2</u> (2) _____ CS/MD 6.5V
3-25-05	6	7:12 7:42	Manual (1) <u>1</u> (2) _____ Pick Up Counter (1) <u>1</u> (2) _____ CS/MD 6.6V

Sketch

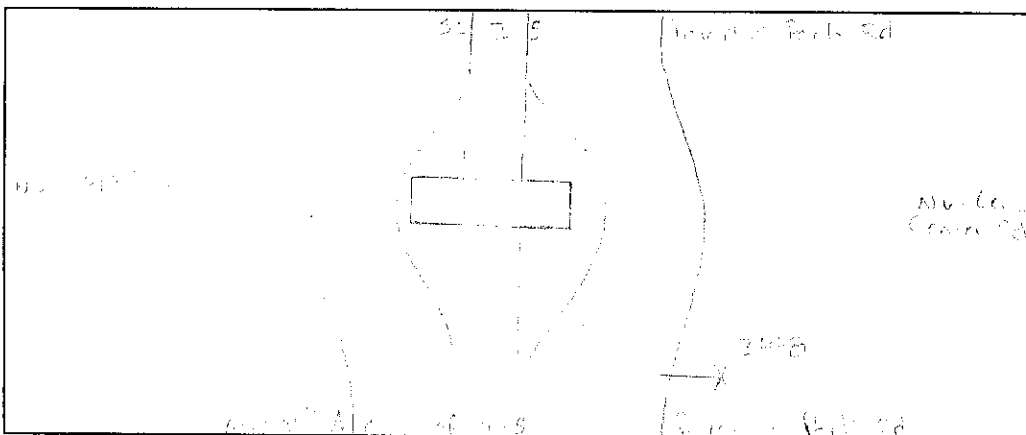

C. Shelton / J. Dietz
Field Person

SR 005 MP 016.80 OFF SYSTEM ID. B LEG S DIRECTION OF TRAFFIC SOUTHBOUND LANE ALL OF

COUNT IDENTIFIER 05-006 COUNTER NUMBER 006484 DESCRIPTION: ON PARADISE PARK RD S/O LA CENTER RD

03/24/05 THURSDAY	AM HOURS												PM HOURS					DAILY TOTAL							
	1	2	3	4	5	6	7	8	9	10	11	12	1	2	3	4	5		6	7	8	9	10	11	12
12	1	2	3	4	5	6	7	8	9	10	11	12	1	2	3	4	5	6	7	8	9	10	11	12	92
1	2	3	4	5	6	7	8	9	10	11	12	1	2	3	4	5	6	7	8	9	10	11	12	158	
TOT	1	2	3	4	5	6	7	8	9	10	11	12	1	2	3	4	5	6	7	8	9	10	11	12	250

AM PEAK HOUR 0945 TO 1045 VOLUME 20
 PM PEAK HOUR 0115 TO 0215 VOLUME 30

03/25/05 FRIDAY	AM HOURS												PM HOURS					DAILY TOTAL							
	1	2	3	4	5	6	7	8	9	10	11	12	1	2	3	4	5		6	7	8	9	10	11	12
12	1	2	3	4	5	6	7	8	9	10	11	12	1	2	3	4	5	6	7	8	9	10	11	12	17
1	2	3	4	5	6	7	8	9	10	11	12	1	2	3	4	5	6	7	8	9	10	11	12	0	
TOT	1	2	3	4	5	6	7	8	9	10	11	12	1	2	3	4	5	6	7	8	9	10	11	12	17

AM PEAK HOUR 0530 TO 0630 VOLUME 8
 PM PEAK HOUR 0000 TO 0000 VOLUME 0

03/21/05 THRU 03/25/05 TOTAL HOURS FOR COUNT 91
 3 DAYS AVG WEEKDAY VOL 221 X SEASONAL ADJ. FACTOR 1.0000 = 221 X AXLE CORR FACTOR 1.0000 = ESTIMATED AVG DAILY TRAFFIC 221

DOT-RNB515A-B

STATE OF WASHINGTON - DEPARTMENT OF TRANSPORTATION
TRIP SYSTEM
15 MINUTE TRAFFIC COUNT SUMMARY

DATE 03/30/05
TIME 13:40:32
PAGE 42

SR 005 MP 016.80 OFF SYSTEM ID. B LEG S DIRECTION OF TRAFFIC NORTHBOUND LANE ALL OF
COUNT IDENTIFIER 05-006 COUNTER NUMBER 003448 DESCRIPTION: ON PARADISE PARK RD S/O LA CENTER RD

03/21/05 MONDAY	12	1	2	3	4	5	6	7	8	9	10	11	12	1	2	3	4	5	6	7	8	9	10	11	12	DAILY TOTAL
00-15																										
15-30																										
30-45																										
45-00																										
HOUR																										
TOT																										130

AM PEAK HOUR 0000 TO 0000 VOLUME 0
PM PEAK HOUR 0500 TO 0600 VOLUME 22

03/22/05 TUESDAY	12	1	2	3	4	5	6	7	8	9	10	11	12	1	2	3	4	5	6	7	8	9	10	11	12	DAILY TOTAL
00-15																										
15-30																										
30-45																										
45-00																										
HOUR																										
TOT																										226

AM PEAK HOUR 1000 TO 1100 VOLUME 22
PM PEAK HOUR 0145 TO 0245 VOLUME 29

03/23/05 WEDNESDAY	12	1	2	3	4	5	6	7	8	9	10	11	12	1	2	3	4	5	6	7	8	9	10	11	12	DAILY TOTAL
00-15																										
15-30																										
30-45																										
45-00																										
HOUR																										
TOT																										202

AM PEAK HOUR 1015 TO 1115 VOLUME 20
PM PEAK HOUR 1200 TO 0100 VOLUME 24

STATE OF WASHINGTON - DEPARTMENT OF TRANSPORTATION
TRIP SYSTEM
15 MINUTE TRAFFIC COUNT SUMMARY

SR 005 MP 016.80 OFF SYSTEM ID. B LEG S DIRECTION OF TRAFFIC NORTHBOUND LANE ALL OF

COUNT IDENTIFIER 05-006 COUNTER NUMBER 003448 DESCRIPTION: ON PARADISE PARK RD S/O LA CENTER RD

03/24/05 THURSDAY	AM HOURS	PM HOURS	AM TOTAL	PM TOTAL	DAILY TOTAL
12	1	2	3	4	7
1	2	3	4	5	9
	3	4	5	6	10
	4	5	6	7	11
	5	6	7	8	12
	6	7	8	9	13
	7	8	9	10	14
	8	9	10	11	15
	9	10	11	12	16
	10	11	12	1	17
	11	12	1	2	18
	12	1	2	3	19
	1	2	3	4	20
	2	3	4	5	21
	3	4	5	6	22
	4	5	6	7	23
	5	6	7	8	24
	6	7	8	9	25
	7	8	9	10	26
	8	9	10	11	27
	9	10	11	12	28
	10	11	12	1	29
	11	12	1	2	30
	12	1	2	3	31
	1	2	3	4	32
	2	3	4	5	33
	3	4	5	6	34
	4	5	6	7	35
	5	6	7	8	36
	6	7	8	9	37
	7	8	9	10	38
	8	9	10	11	39
	9	10	11	12	40
	10	11	12	1	41
	11	12	1	2	42
	12	1	2	3	43
	1	2	3	4	44
	2	3	4	5	45
	3	4	5	6	46
	4	5	6	7	47
	5	6	7	8	48
	6	7	8	9	49
	7	8	9	10	50
	8	9	10	11	51
	9	10	11	12	52
	10	11	12	1	53
	11	12	1	2	54
	12	1	2	3	55
	1	2	3	4	56
	2	3	4	5	57
	3	4	5	6	58
	4	5	6	7	59
	5	6	7	8	60
	6	7	8	9	61
	7	8	9	10	62
	8	9	10	11	63
	9	10	11	12	64
	10	11	12	1	65
	11	12	1	2	66
	12	1	2	3	67
	1	2	3	4	68
	2	3	4	5	69
	3	4	5	6	70
	4	5	6	7	71
	5	6	7	8	72
	6	7	8	9	73
	7	8	9	10	74
	8	9	10	11	75
	9	10	11	12	76
	10	11	12	1	77
	11	12	1	2	78
	12	1	2	3	79
	1	2	3	4	80
	2	3	4	5	81
	3	4	5	6	82
	4	5	6	7	83
	5	6	7	8	84
	6	7	8	9	85
	7	8	9	10	86
	8	9	10	11	87
	9	10	11	12	88
	10	11	12	1	89
	11	12	1	2	90
	12	1	2	3	91
	1	2	3	4	92
	2	3	4	5	93
	3	4	5	6	94
	4	5	6	7	95
	5	6	7	8	96
	6	7	8	9	97
	7	8	9	10	98
	8	9	10	11	99
	9	10	11	12	100
	10	11	12	1	101
	11	12	1	2	102
	12	1	2	3	103
	1	2	3	4	104
	2	3	4	5	105
	3	4	5	6	106
	4	5	6	7	107
	5	6	7	8	108
	6	7	8	9	109
	7	8	9	10	110
	8	9	10	11	111
	9	10	11	12	112
	10	11	12	1	113
	11	12	1	2	114
	12	1	2	3	115
	1	2	3	4	116
	2	3	4	5	117
	3	4	5	6	118
	4	5	6	7	119
	5	6	7	8	120
	6	7	8	9	121
	7	8	9	10	122
	8	9	10	11	123
	9	10	11	12	124
	10	11	12	1	125
	11	12	1	2	126
	12	1	2	3	127
	1	2	3	4	128
	2	3	4	5	129
	3	4	5	6	130
	4	5	6	7	131
	5	6	7	8	132
	6	7	8	9	133
	7	8	9	10	134
	8	9	10	11	135
	9	10	11	12	136
	10	11	12	1	137
	11	12	1	2	138
	12	1	2	3	139
	1	2	3	4	140
	2	3	4	5	141
	3	4	5	6	142
	4	5	6	7	143
	5	6	7	8	144
	6	7	8	9	145
	7	8	9	10	146
	8	9	10	11	147
	9	10	11	12	148
	10	11	12	1	149
	11	12	1	2	150
	12	1	2	3	151
	1	2	3	4	152
	2	3	4	5	153
	3	4	5	6	154
	4	5	6	7	155
	5	6	7	8	156
	6	7	8	9	157
	7	8	9	10	158
	8	9	10	11	159
	9	10	11	12	160
	10	11	12	1	161
	11	12	1	2	162
	12	1	2	3	163
	1	2	3	4	164
	2	3	4	5	165
	3	4	5	6	166
	4	5	6	7	167
	5	6	7	8	168
	6	7	8	9	169
	7	8	9	10	170
	8	9	10	11	171
	9	10	11	12	172
	10	11	12	1	173
	11	12	1	2	174
	12	1	2	3	175
	1	2	3	4	176
	2	3	4	5	177
	3	4	5	6	178
	4	5	6	7	179
	5	6	7	8	180
	6	7	8	9	181
	7	8	9	10	182
	8	9	10	11	183
	9	10	11	12	184
	10	11	12	1	185
	11	12	1	2	186
	12	1	2	3	187
	1	2	3	4	188
	2	3	4	5	189
	3	4	5	6	190
	4	5	6	7	191
	5	6	7	8	192
	6	7	8	9	193
	7	8	9	10	194
	8	9	10	11	195
	9	10	11	12	196
	10	11	12	1	197
	11	12	1	2	198
	12	1	2	3	199
	1	2	3	4	200
	2	3	4	5	201
	3	4	5	6	202
	4	5	6	7	203
	5	6	7	8	204
	6	7	8	9	205
	7	8	9	10	206
	8	9	10	11	207
	9	10	11	12	208
	10	11	12	1	209
	11	12	1	2	210
	12	1	2	3	211
	1	2	3	4	212
	2	3	4	5	213
	3	4	5	6	214
	4	5	6	7	215
	5	6	7	8	216
	6	7	8	9	217
	7	8	9	10	218
	8	9	10	11	219
	9	10	11	12	220
	10	11	12	1	221
	11	12	1	2	222
	12	1	2	3	223
	1	2	3	4	224
	2	3	4	5	225
	3	4	5	6	226
	4	5	6	7	227
	5	6	7	8	228
	6	7	8	9	229
	7	8	9	10	230
	8	9	10	11	231
	9	10	11	12	232
	10	11	12	1	233
	11	12	1	2	234
	12	1	2	3	235
	1	2	3	4	236
	2	3	4	5	237
	3	4	5	6	238
	4	5	6	7	239
	5	6	7	8	240
	6	7	8	9	241
	7	8	9	10	242
	8	9	10	11	243
	9	10	11	12	244
	10	11	12	1	245
	11	12	1	2	246
	12	1	2	3	247
	1	2	3	4	248
	2	3	4	5	249
	3	4	5	6	250
	4	5	6	7	251
	5	6	7	8	252
	6	7	8	9	253
	7	8	9	10	254
	8	9	10	11	255
	9	10	11	12	256
	10	11	12	1	257
	11	12	1	2	258
	12	1	2	3	259
	1	2	3	4	260
	2	3	4	5	261
	3	4	5	6	262
	4	5	6	7	263
	5	6	7	8	264
	6	7	8	9	265
	7	8	9	10	266
	8	9	10	11	267
	9	10	11	12	268
	10	11	12	1	269
	11	12	1	2	270
	12	1	2	3	271
	1	2	3	4	272
	2	3	4	5	273
	3	4	5	6	274
	4	5	6	7	275
	5	6	7	8	276
	6	7	8	9	277
	7	8	9	10	278
	8	9	10	11	279
	9	10	11	12	280
	10	11	12	1	281
	11	12	1	2	282
	12	1	2	3	283
	1	2	3	4	284
	2	3	4	5	285
	3	4	5	6	286
	4	5	6	7	287
	5	6	7	8	288
	6	7	8	9	289
	7	8	9	10	290
	8	9	10	11	291
	9	10	11	12	292
	10	11	12	1	293
	11	12	1	2	294

STATE OF WASHINGTON - DEPARTMENT OF TRANSPORTATION
TRIP SYSTEM
15 MINUTE TRAFFIC COUNT SUMMARY

SR 005 MP 016.80 OFF SYSTEM ID. B LEG S DIRECTION OF TRAFFIC BOTH WAYS LANE ALL OF
COUNT IDENTIFIER 05-006 COUNTER NUMBER 003448 DESCRIPTION: ON PARADISE PARK RD S/O LA CENTER RD

03/21/05	AM HOURS												PM HOURS												DAILY TOTAL									
	12	1	2	3	4	5	6	7	8	9	10	11	12	1	2	3	4	5	6	7	8	9	10	11		12								
00-15													18	12	9	8	9	11	11	4	3	1	1	2										
15-30													6	9	11	11	6	14	3	2	2	1	1											
30-45													7	9	8	17	8	10	7	1	1	2												
45-00													9	13	8	6	7	9	1	5	1	1	1											
HOUR																																		
TOT	40												43												36	42	30	44	15	11	4	2	3	269 270

03/22/05	AM HOURS												PM HOURS												DAILY TOTAL										
	12	1	2	3	4	5	6	7	8	9	10	11	12	1	2	3	4	5	6	7	8	9	10	11		12									
00-15													4	8	10	10	6	8	13	6	10	12	3	3	2										
15-30													5	6	6	12	3	6	11	8	11	16	5	8	1										
30-45													5	5	5	8	6	11	4	4	14	5	8	1											
45-00													6	6	8	6	17	9	9	9	9	8	1	1	1										
HOUR																																			
TOT	20												25												38	40	47	42	22	6	2	2	4	2	433 434

03/23/05	AM HOURS												PM HOURS												DAILY TOTAL																		
	12	1	2	3	4	5	6	7	8	9	10	11	12	1	2	3	4	5	6	7	8	9	10	11		12																	
00-15													3	7	7	9	12	9	13	12	3	8	5	9	2																		
15-30													2	2	5	3	6	11	11	9	4	9	13	11	3																		
30-45													1	1	2	2	7	9	7	7	7	7	10	6	7																		
45-00													1	1	1	3	6	13	10	4	11	8	11	6	1																		
HOUR																																											
TOT	14												17												24	20	44	34	43	32	25	35	36	37	21	7	3	1	6	1	161	247	408

STATE OF WASHINGTON - DEPARTMENT OF TRANSPORTATION
TRIP SUMMARY
15 MINUTE TRAFFIC COUNT SUMMARY

SR 005 MP 016.80 OFF SYSTEM ID. B LEG S DIRECTION OF TRAFFIC BOTH WAYS LANE ALL OF

COUNT IDENTIFIER 05-006 COUNTER NUMBER 003448 DESCRIPTION: ON PARADISE PARK RD S/O LA CENTER RD

03/24/05 THURSDAY	AM HOURS												PM HOURS												DAILY TOTAL
	1	2	3	4	5	6	7	8	9	10	11	12	1	2	3	4	5	6	7	8	9	10	11	12	
12	1	2	3	4	5	6	7	8	9	10	11	12	1	2	3	4	5	6	7	8	9	10	11	12	188
1	2	3	4	5	6	7	8	9	10	11	12	1	2	3	4	5	6	7	8	9	10	11	12	188	
TOT	1	1	1	1	1	1	1	1	1	1	1	1	1	1	1	1	1	1	1	1	1	1	1	503	

AM PEAK HOUR 1015 TO 1115 VOLUME 44
PM PEAK HOUR 0415 TO 0515 VOLUME 55

03/25/05 FRIDAY	AM HOURS												PM HOURS												DAILY TOTAL
	1	2	3	4	5	6	7	8	9	10	11	12	1	2	3	4	5	6	7	8	9	10	11	12	
12	1	2	3	4	5	6	7	8	9	10	11	12	1	2	3	4	5	6	7	8	9	10	11	12	33
1	2	3	4	5	6	7	8	9	10	11	12	1	2	3	4	5	6	7	8	9	10	11	12	33	
TOT	1	1	1	1	1	1	1	1	1	1	1	1	1	1	1	1	1	1	1	1	1	1	1	1	33

AM PEAK HOUR 0600 TO 0700 VOLUME 12
PM PEAK HOUR 0000 TO 0000 VOLUME 0

3 DAYS
 AVG WEEKDAY VOL 448 X SEASONAL ADJ. FACTOR 1.0000 = 448 X AXLE CORR FACTOR 1.0000 = ESTIMATED AVG DAILY TRAFFIC 448
 PEAK HOUR PERCENTAGES: K = 12.28 D = 50.96
 PEAK HOUR LOCATION : VOLUME = 55 DATE: 03/24/05 TIME: 04:15 PM



Interval 60 min. 15 min.

Count(volume) Speed

Binned(CL/SP) Raw

Lane No 1 2

Direction Channel 1 _____

Direction Channel 2 _____

Data Hog # 7064

Counter No. 1656-13 Count ID SP#05-006

SR 005 RRT/RRQ fl Temp MP 16.80

Leg N Direction SB OSID (B)

Station Description ON Paradise Park Rd N/O La Center Rd

Date	Day	Time	Comments
3-21-05	2	12:15	Manual (1) <u>1</u> (2) Set Ok Counter (1) <u>1</u> (2) CS/MD 6.7V
3-22-05	3	7:42	Manual (1) <u>2</u> (2) Check Ok Counter (1) <u>2</u> (2) CS/MD 6.4V
3-23-05	4	10:19	Manual (1) <u>1</u> (2) Check Ok Counter (1) <u>1sv</u> (2) CS/MD 6.4V
3-24-05	5	8:01	Manual (1) <u>1</u> (2) Check Ok Counter (1) <u>1</u> (2) CS/MD 6.3V
3-25-05	6	7:57	Manual (1) (2) Pick Up Counter (1) (2) CS/MD 6.3V

Sketch

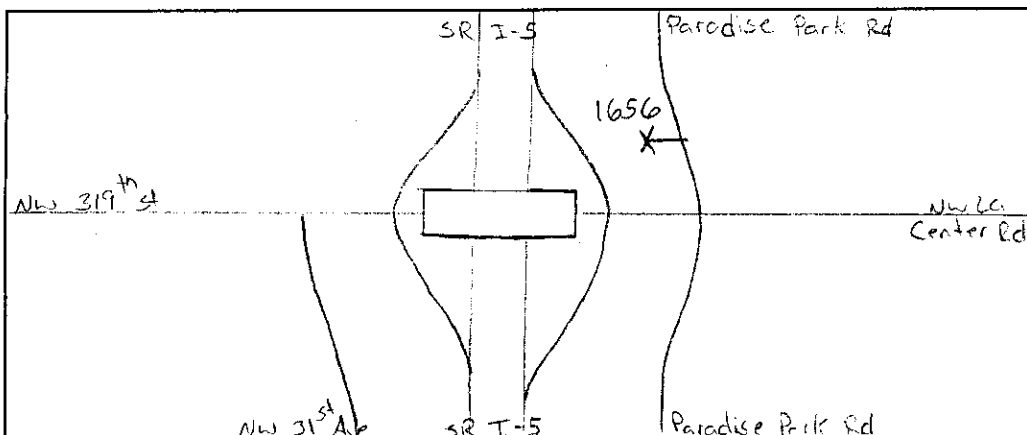

C. Shelton / M. Dietz
Field Person



Interval 60 min. 15 min.

Count(volume) Speed

Binned(CL/SP) Raw

Lane No 1 2

Direction Channel 1 _____

Direction Channel 2 _____

Data Hog # 7064

Counter No. 1550-13 Count ID SP#05-006

SR 005 RRT/RRQ ft Temp MP 16.80

Leg N Direction NB OSID B

Station Description _ ON Paradise Park Rd N/O La Center Rd

Date	Day	Time	Comments
3-21-05	2	12:13	Manual (1) <u>1</u> (2) _____ Set Ok Counter (1) <u>1</u> (2) _____ CS/MD 6.7V
3-22-05	3	7:41	Manual (1) <u>1</u> (2) _____ Check Ok Counter (1) <u>1sv</u> (2) _____ CS/MD 6.4V
3-23-05	4	10:19	Manual (1) <u>1</u> (2) _____ Check Ok Counter (1) <u>1sv</u> (2) _____ CS/MD 6.4V
3-24-05	5	8:00	Manual (1) <u>1</u> (2) _____ Check Ok Counter (1) <u>1sv</u> (2) _____ CS/MD 6.4V
3-25-05	6	7:55	Manual (1) <u>1</u> (2) _____ Pick Up Counter (1) <u>1</u> (2) _____ CS/MD 6.4V

Sketch

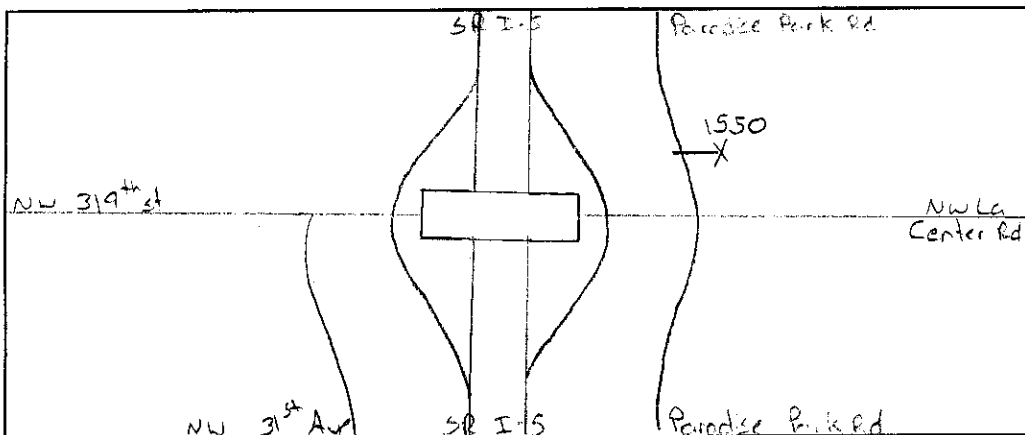

C. Shelton / M. Dietz
Field Person

SR 005 MP 016.80 OFF SYSTEM ID. B LEG N DIRECTION OF TRAFFIC SOUTHBOUND LANE ALL OF

COUNT IDENTIFIER 05-006 COUNTER NUMBER 001656 DESCRIPTION: ON PARADISE PARK RD N/O LA CENTER RD

03/24/05 THURSDAY	AM HOURS	PM HOURS	AM TOTAL	PM TOTAL	DAILY TOTAL
12	1	2	3	4	7
1	2	3	5	6	11
	3	4	7	8	15
	4	5	9	10	19
	5	6	11	12	23
	6	7	13	14	27
	7	8	15	16	31
	8	9	17	18	35
	9	10	19	20	39
	10	11	21	22	43
	11	12	23	24	47
	12	1	25	26	51
	1	2	27	28	55
	2	3	29	30	59
	3	4	31	32	63
	4	5	33	34	67
	5	6	35	36	71
	6	7	37	38	75
	7	8	39	40	79
	8	9	41	42	83
	9	10	43	44	87
	10	11	45	46	91
	11	12	47	48	95
	12	1	49	50	99
	1	2	51	52	103
	2	3	53	54	107
	3	4	55	56	111
	4	5	57	58	115
	5	6	59	60	119
	6	7	61	62	123
	7	8	63	64	127
	8	9	65	66	131
	9	10	67	68	135
	10	11	69	70	139
	11	12	71	72	143
	12	1	73	74	147
	1	2	75	76	151
	2	3	77	78	155
	3	4	79	80	159
	4	5	81	82	163
	5	6	83	84	167
	6	7	85	86	171
	7	8	87	88	175
	8	9	89	90	179
	9	10	91	92	183
	10	11	93	94	187
	11	12	95	96	191
	12	1	97	98	195
	1	2	99	100	199
	2	3	101	102	203
	3	4	103	104	207
	4	5	105	106	211
	5	6	107	108	215
	6	7	109	110	219
	7	8	111	112	223
	8	9	113	114	227
	9	10	115	116	231
	10	11	117	118	235
	11	12	119	120	239
	12	1	121	122	243
	1	2	123	124	247
	2	3	125	126	251
	3	4	127	128	255
	4	5	129	130	259
	5	6	131	132	263
	6	7	133	134	267
	7	8	135	136	271
	8	9	137	138	275
	9	10	139	140	279
	10	11	141	142	283
	11	12	143	144	287
	12	1	145	146	291
	1	2	147	148	295
	2	3	149	150	299
	3	4	151	152	303
	4	5	153	154	307
	5	6	155	156	311
	6	7	157	158	315
	7	8	159	160	319
	8	9	161	162	323
	9	10	163	164	327
	10	11	165	166	331
	11	12	167	168	335
	12	1	169	170	339
	1	2	171	172	343
	2	3	173	174	347
	3	4	175	176	351
	4	5	177	178	355
	5	6	179	180	359
	6	7	181	182	363
	7	8	183	184	367
	8	9	185	186	371
	9	10	187	188	375
	10	11	189	190	379
	11	12	191	192	383
	12	1	193	194	387
	1	2	195	196	391
	2	3	197	198	395
	3	4	199	200	399
	4	5	201	202	403
	5	6	203	204	407
	6	7	205	206	411
	7	8	207	208	415
	8	9	209	210	419
	9	10	211	212	423
	10	11	213	214	427
	11	12	215	216	431
	12	1	217	218	435
	1	2	219	220	439
	2	3	221	222	443
	3	4	223	224	447
	4	5	225	226	451
	5	6	227	228	455
	6	7	229	230	459
	7	8	231	232	463
	8	9	233	234	467
	9	10	235	236	471
	10	11	237	238	475
	11	12	239	240	479
	12	1	241	242	483
	1	2	243	244	487
	2	3	245	246	491
	3	4	247	248	495
	4	5	249	250	499
	5	6	251	252	503
	6	7	253	254	507
	7	8	255	256	511
	8	9	257	258	515
	9	10	259	260	519
	10	11	261	262	523
	11	12	263	264	527
	12	1	265	266	531
	1	2	267	268	535
	2	3	269	270	539
	3	4	271	272	543
	4	5	273	274	547
	5	6	275	276	551
	6	7	277	278	555
	7	8	279	280	559
	8	9	281	282	563
	9	10	283	284	567
	10	11	285	286	571
	11	12	287	288	575
	12	1	289	290	579
	1	2	291	292	583
	2	3	293	294	587
	3	4	295	296	591
	4	5	297	298	595
	5	6	299	300	599
	6	7	301	302	603
	7	8	303	304	607
	8	9	305	306	611
	9	10	307	308	615
	10	11	309	310	619
	11	12	311	312	623
	12	1	313	314	627
	1	2	315	316	631
	2	3	317	318	635
	3	4	319	320	639
	4	5	321	322	643
	5	6	323	324	647
	6	7	325	326	651
	7	8	327	328	655
	8	9	329	330	659
	9	10	331	332	663
	10	11	333	334	667
	11	12	335	336	671
	12	1	337	338	675
	1	2	339	340	679
	2	3	341	342	683
	3	4	343	344	687
	4	5	345	346	691
	5	6	347	348	695
	6	7	349	350	699
	7	8	351	352	703
	8	9	353	354	707
	9	10	355	356	711
	10	11	357	358	715
	11	12	359	360	719
	12	1	361	362	723
	1	2	363	364	727
	2	3	365	366	731
	3	4	367	368	735
	4	5	369	370	739
	5	6	371	372	743
	6	7	373	374	747
	7	8	375	376	751
	8	9	377	378	755
	9	10	379	380	759
	10	11	381	382	763
	11	12	383	384	767
	12	1	385	386	771
	1	2	387	388	775
	2	3	389	390	779
	3	4	391	392	783
	4	5	393	394	787
	5	6	395	396	791
	6	7	397	398	795
	7	8	399	400	799
	8	9	401	402	803
	9	10	403	404	807
	10	11	405	406	811
	11	12	407	408	815
	12	1	409	410	819
	1	2	411	412	823
	2	3	413	414	827
	3	4	415	416	831
	4	5	417	418	835
	5	6	419	420	839
	6	7	421	422	843
	7	8	423	424	847
	8	9	425	426	851
	9	10	427	428	855
	10	11	429	430	859
	11	12	431	432	863
	12	1	433	434	867
	1	2	435	436	871
	2	3	437	438	875
	3	4	439	440	879
	4	5	441	442	883
	5	6	443	444	887
	6	7	445	446	891
	7	8	447	448	895
	8	9	449	450	899
	9	10	451	452	903
	10	11	453	454	907
	11	12	455	456	911
	12	1	457	458	915
	1	2	459	460	919
	2	3	461	462	923
	3	4	463	464	927
	4	5	465	466	931
	5	6	467	468	935
	6	7	469	470	939
	7	8	471	472	943
	8	9	473	474	947
	9	10	475	476	951
	10	11	477	478	955
	11	12	479	480	959
	12	1	481	482	963
	1	2	483	484	967
	2	3	485	486	971
	3	4	487	488	975
	4	5	489	490	979
	5	6	491	492	983
	6	7	493	494	987
	7	8	495	496	991
	8	9	497	498	995
	9	10	499	500	999
	10	11	501	502	1003
	11	12	503	504	1007
	12	1	505	506	1011
	1	2	507	508	1015
	2	3	509	510	1019
	3	4	511	512	1023
	4	5	513	514	1027
	5	6	515	516	1031
	6	7	517	518	1035
	7	8	519	520	1039
	8	9	521	522	1043
	9	10	523	524	1047
	10	11	525	526	1051
	11	12	527	528	1055
	12	1	529	530	1059
	1	2	531	532	1063
	2	3			

STATE OF WASHINGTON - DEPARTMENT OF TRANSPORTATION
TRIP SYSTEM
15 MINUTE TRAFFIC COUNT SUMMARY

SR 005 MP 016.80 OFF SYSTEM ID. B LEG N DIRECTION OF TRAFFIC NORTHBOUND LANE ALL OF

COUNT IDENTIFIER 05-006 COUNTER NUMBER 001550 DESCRIPTION: ON PARADISE PARK RD N/O LA CENTER RD

03/21/05	MONDAY	AM HOURS												PM HOURS												DAILY TOTAL
		1	2	3	4	5	6	7	8	9	10	11	12	1	2	3	4	5	6	7	8	9	10	11	12	
00-15	1	2	3	4	5	6	7	8	9	10	11	12	1	2	3	5	2	2	2	1	1	1	1	1		
15-30	1	2	3	4	5	6	7	8	9	10	11	12	1	2	3	3	2	2	1	1	1	1	1	1		
30-45	1	2	3	4	5	6	7	8	9	10	11	12	1	2	3	3	2	2	1	1	1	1	1	1		
45-00	1	2	3	4	5	6	7	8	9	10	11	12	1	2	3	3	2	2	1	1	1	1	1	1		
TOT	1	2	3	4	5	6	7	8	9	10	11	12	7	11	10	9	9	16	1	2	2	2	1	1	78	
		AM PEAK HOUR 0000 TO 0000 VOLUME												PM PEAK HOUR 0600 TO 0700 VOLUME												AM TOTAL
		0												16												0
		PM PEAK HOUR 0600 TO 0700 VOLUME												16												78

03/22/05	TUESDAY	AM HOURS												PM HOURS												DAILY TOTAL
		1	2	3	4	5	6	7	8	9	10	11	12	1	2	3	4	5	6	7	8	9	10	11	12	
00-15	1	2	3	4	5	6	7	8	9	10	11	12	1	2	2	2	1	1	1	1	1	1	1	1		
15-30	1	2	3	4	5	6	7	8	9	10	11	12	1	2	2	2	1	1	1	1	1	1	1	1		
30-45	1	2	3	4	5	6	7	8	9	10	11	12	1	2	2	2	1	1	1	1	1	1	1	1		
45-00	1	2	3	4	5	6	7	8	9	10	11	12	1	2	2	2	1	1	1	1	1	1	1	1		
TOT	1	2	3	4	5	6	7	8	9	10	11	12	3	5	4	8	6	4	7	11	6	13	6	4	2	89
		AM PEAK HOUR 0730 TO 0830 VOLUME												PM PEAK HOUR 0545 TO 0645 VOLUME												AM TOTAL
		2												7												22
		PM PEAK HOUR 0545 TO 0645 VOLUME												7												67

03/23/05	WEDNESDAY	AM HOURS												PM HOURS												DAILY TOTAL
		1	2	3	4	5	6	7	8	9	10	11	12	1	2	3	4	5	6	7	8	9	10	11	12	
00-15	1	2	3	4	5	6	7	8	9	10	11	12	1	2	2	2	1	1	1	1	1	1	1	1		
15-30	1	2	3	4	5	6	7	8	9	10	11	12	1	2	2	2	1	1	1	1	1	1	1	1		
30-45	1	2	3	4	5	6	7	8	9	10	11	12	1	2	2	2	1	1	1	1	1	1	1	1		
45-00	1	2	3	4	5	6	7	8	9	10	11	12	1	2	2	2	1	1	1	1	1	1	1	1		
TOT	2	3	4	5	6	7	8	9	10	11	12	14	5	6	5	14	5	6	11	6	13	3	3	2	2	98
		AM PEAK HOUR 1100 TO 1200 VOLUME												PM PEAK HOUR 1200 TO 0100 VOLUME												AM TOTAL
		10												14												34
		PM PEAK HOUR 1200 TO 0100 VOLUME												14												64

SR 005 MP 016.80 OFF SYSTEM ID. B LEG N DIRECTION OF TRAFFIC NORTHBOUND LANE ALL OF

COUNT IDENTIFIER 05-006 COUNTER NUMBER 001550 DESCRIPTION: ON PARADISE PARK RD N/O LA CENTER RD

03/24/05 THURSDAY	AM HOURS												PM HOURS												DAILY TOTAL
	1	2	3	4	5	6	7	8	9	10	11	12	1	2	3	4	5	6	7	8	9	10	11	12	
12	1	2	3	4	5	6	7	8	9	10	11	12	1	2	3	4	5	6	7	8	9	10	11	12	107
1	2	3	4	5	6	7	8	9	10	11	12	1	2	3	4	5	6	7	8	9	10	11	12	34	
1	1	1	1	1	1	1	1	1	1	1	1	1	1	1	1	1	1	1	1	1	1	1	1	73	
1	1	1	1	1	1	1	1	1	1	1	1	1	1	1	1	1	1	1	1	1	1	1	1	107	
TOT	2	1	1	1	1	1	1	1	1	1	1	1	1	1	1	1	1	1	1	1	1	1	1	107	

AM PEAK HOUR 0700 TO 0800 VOLUME 9
PM PEAK HOUR 0430 TO 0530 VOLUME 14

03/25/05 FRIDAY	AM HOURS												PM HOURS												DAILY TOTAL
	1	2	3	4	5	6	7	8	9	10	11	12	1	2	3	4	5	6	7	8	9	10	11	12	
12	1	2	3	4	5	6	7	8	9	10	11	12	1	2	3	4	5	6	7	8	9	10	11	12	3
1	2	3	4	5	6	7	8	9	10	11	12	1	2	3	4	5	6	7	8	9	10	11	12	3	
1	1	1	1	1	1	1	1	1	1	1	1	1	1	1	1	1	1	1	1	1	1	1	1	1	3
TOT	1	1	1	1	1	1	1	1	1	1	1	1	1	1	1	1	1	1	1	1	1	1	1	1	3

AM PEAK HOUR 0045 TO 0145 VOLUME 1
PM PEAK HOUR 0000 TO 0000 VOLUME 0

03/21/05 THRU 03/25/05 TOTAL HOURS FOR COUNT 89
3 DAYS AVG WEEKDAY VOL 98 X SEASONAL ADJ. FACTOR 1.0000 = 98 X AXLE CORR FACTOR 1.0000 = ESTIMATED AVG DAILY TRAFFIC 98

STATE OF WASHINGTON - DEPARTMENT OF TRANSPORTATION
TRIP SYSTEM
15 MINUTE TRAFFIC COUNT SUMMARY

SR 005 MP 016.80 OFF SYSTEM ID. B LEG N DIRECTION OF TRAFFIC BOTH WAYS LANE ALL OF
COUNT IDENTIFIER 05-006 COUNTER NUMBER 001550 DESCRIPTION: ON PARADISE PARK RD N/O LA CENTER RD

03/24/05	THURSDAY	AM HOURS												PM HOURS												DAILY TOTAL
		1	2	3	4	5	6	7	8	9	10	11	12	1	2	3	4	5	6	7	8	9	10	11	12	
12	1	2	3	4	5	6	7	8	9	10	11	12	1	2	3	4	5	6	7	8	9	10	11	12	83	
1	2	3	4	5	6	7	8	9	10	11	12	1	2	3	4	5	6	7	8	9	10	11	12	133		
00-15																									1	
15-30																									4	
30-45																									1	
45-00																									1	
TOT	4	2																							216	

AM PEAK HOUR 0745 TO 0845 VOLUME 20
PM PEAK HOUR 1230 TO 0130 VOLUME 22

AM TOTAL 83
PM TOTAL 133

03/25/05	FRIDAY	AM HOURS												PM HOURS												DAILY TOTAL
		1	2	3	4	5	6	7	8	9	10	11	12	1	2	3	4	5	6	7	8	9	10	11	12	
12	1	2	3	4	5	6	7	8	9	10	11	12	1	2	3	4	5	6	7	8	9	10	11	12	7	
1	2	3	4	5	6	7	8	9	10	11	12	1	2	3	4	5	6	7	8	9	10	11	12	0		
00-15																									1	
15-30																									3	
30-45																									0	
45-00																									0	
TOT	2																								7	

AM PEAK HOUR 0400 TO 0500 VOLUME 3
PM PEAK HOUR 0000 TO 0000 VOLUME 0

AM TOTAL 7
PM TOTAL 0

03/21/05 THRU 03/25/05
TOTAL HOURS FOR COUNT 89

3 DAYS AVG WEEKDAY VOL 197 X SEASONAL ADJ. FACTOR 1.0000 = 197 X AXLE CORR FACTOR 1.0000 = ESTIMATED AVG DAILY TRAFFIC 197
PEAK HOUR PERCENTAGES: K = 12.18 D = 58.33
PEAK HOUR LOCATION : VOLUME = 24 DATE: 03/21/05 TIME: 02:00 PM