

**LOCATION:** NE 143rd Ave -- NE Fourth Plain Rd  
**CITY/STATE:** Vancouver, WA

**QC JOB #:** 14655103  
**DATE:** Wed, Mar 21 2018

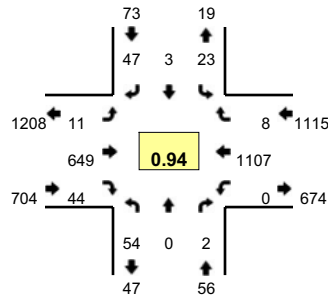

**Peak-Hour: 7:20 AM -- 8:20 AM**  
**Peak 15-Min: 7:35 AM -- 7:50 AM**

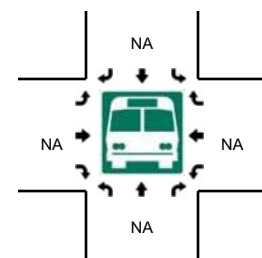
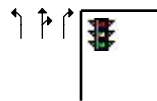
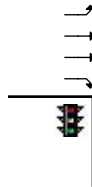
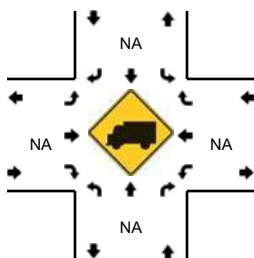
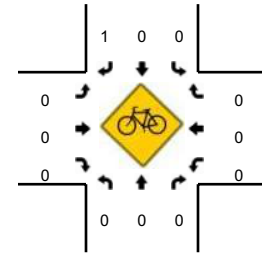
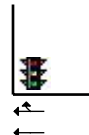
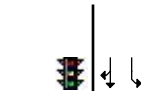
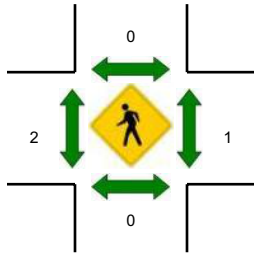
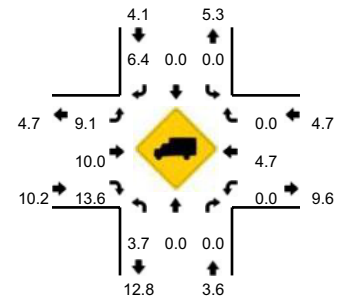

5-Min Count Period Beginning At	NE 143rd Ave (Northbound)				NE 143rd Ave (Southbound)				NE Fourth Plain Rd (Eastbound)				NE Fourth Plain Rd (Westbound)				Total	Hourly Totals
	Left	Thru	Right	U	Left	Thru	Right	U	Left	Thru	Right	U	Left	Thru	Right	U		
7:00 AM	7	0	0	0	0	0	7	0	1	43	3	0	0	77	0	0	138	
7:05 AM	3	0	0	0	2	0	2	0	0	30	2	0	0	76	1	0	116	
7:10 AM	5	0	0	0	0	0	3	0	0	46	3	0	0	65	0	0	122	
7:15 AM	1	0	0	0	0	0	2	0	2	47	6	0	0	88	0	0	146	
7:20 AM	6	0	0	0	3	0	7	0	0	52	1	0	0	90	0	0	159	
7:25 AM	3	0	1	0	2	0	2	0	2	64	5	0	0	111	0	0	190	
7:30 AM	2	0	0	0	2	0	1	0	2	50	3	0	0	91	0	0	151	
7:35 AM	6	0	0	0	3	0	2	0	1	54	3	0	0	106	1	0	176	
7:40 AM	3	0	0	0	4	1	4	0	0	65	1	0	0	81	1	0	160	
7:45 AM	2	0	0	0	2	0	5	0	1	60	7	0	0	104	1	0	182	
7:50 AM	7	0	0	0	1	0	3	0	0	66	4	0	0	89	0	0	170	
7:55 AM	2	0	1	0	2	0	6	0	0	57	5	0	0	81	4	0	158	1868
8:00 AM	2	0	0	0	1	0	3	0	1	49	1	0	0	83	1	0	141	1871
8:05 AM	5	0	0	0	2	1	3	0	1	40	4	0	0	81	0	0	137	1892
8:10 AM	8	0	0	0	1	0	7	0	2	47	4	0	0	97	0	0	166	1936
8:15 AM	8	0	0	0	0	1	4	0	1	45	6	0	0	93	0	0	158	1948
8:20 AM	0	0	0	0	0	0	2	0	0	51	5	0	0	84	0	0	142	1931
8:25 AM	8	0	0	0	0	0	2	0	2	40	6	0	0	99	1	0	158	1899
8:30 AM	3	1	2	0	0	0	4	0	0	63	4	0	0	85	0	0	162	1910
8:35 AM	4	0	0	0	1	0	1	0	2	42	8	0	0	101	1	0	160	1894
8:40 AM	7	0	0	0	1	1	3	0	0	59	5	0	0	86	0	0	162	1896
8:45 AM	4	0	0	0	1	0	3	0	3	47	5	0	0	86	0	0	149	1863
8:50 AM	6	0	0	0	1	0	3	0	1	36	4	0	0	74	1	0	126	1819
8:55 AM	0	0	1	0	1	0	2	0	7	51	6	0	0	65	0	0	133	1794
Peak 15-Min Flowrates	Northbound				Southbound				Eastbound				Westbound				Total	
	Left	Thru	Right	U	Left	Thru	Right	U	Left	Thru	Right	U	Left	Thru	Right	U		
All Vehicles	44	0	0	0	36	4	44	0	8	716	44	0	0	1164	12	0	2072	
Heavy Trucks	0	0	0	0	0	0	4	0	0	48	8	0	0	44	0	0	104	
Pedestrians	0	0	0	0	0	0	0	0	0	0	0	0	0	0	0	0	0	
Bicycles	0	0	0	0	0	0	0	0	0	0	0	0	0	0	0	0	0	
Railroad																		
Stopped Buses																		

Comments: