

92nd Ave Mill Plain Blvd

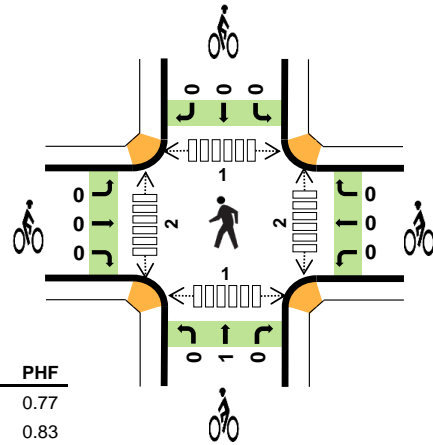

Date: Tue, Sep 21, 2021
 Count Period: 7:00 AM to 9:00 AM
 Peak Hour: 7:30 AM to 8:30 AM

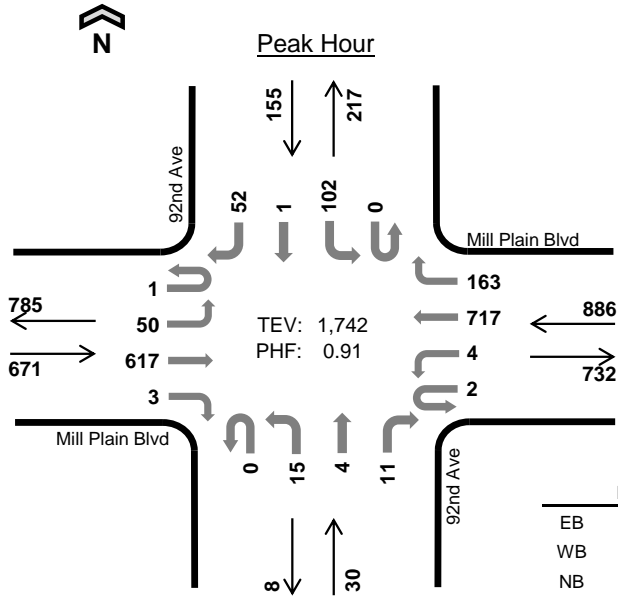

	HV %:	PHF
EB	6.9%	0.77
WB	5.6%	0.83
NB	3.3%	0.83
SB	11.0%	0.82
TOTAL	6.5%	0.91

Two-Hour Count Summaries

Interval Start	Mill Plain Blvd Eastbound				Mill Plain Blvd Westbound				92nd Ave Northbound				92nd Ave Southbound				15-min Total	Rolling One Hour	
	UT	LT	TH	RT	UT	LT	TH	RT	UT	LT	TH	RT	UT	LT	TH	RT			
7:00 AM	0	13	95	0	0	0	117	27	0	0	1	0	0	39	2	21	315	0	
7:15 AM	1	9	122	1	0	0	145	45	0	2	1	0	0	28	2	14	370	0	
7:30 AM	1	11	153	1	0	0	181	51	0	5	0	3	0	22	0	14	442	0	
7:45 AM	0	21	133	1	0	1	201	66	0	3	2	4	0	33	0	14	479	1,606	
8:00 AM	0	7	123	1	2	2	173	33	0	7	0	2	0	29	0	13	392	1,683	
8:15 AM	0	11	208	0	0	1	162	13	0	0	2	2	0	18	1	11	429	1,742	
8:30 AM	2	10	206	2	3	2	152	19	0	4	0	1	0	16	1	10	428	1,728	
8:45 AM	0	7	190	0	0	3	166	11	0	2	2	1	0	8	3	5	398	1,647	
Count Total	4	89	1,230	6	5	9	1,297	265	0	23	8	13	0	193	9	102	3,253	0	
Peak Hour	All	1	50	617	3	2	4	717	163	0	15	4	11	0	102	1	52	1,742	0
	HV	0	4	42	0	0	1	24	25	0	1	0	0	0	16	0	1	114	0
	HV%	0%	8%	7%	0%	0%	25%	3%	15%	-	7%	0%	0%	-	16%	0%	2%	7%	0

Note: Two-hour count summary volumes include heavy vehicles but exclude bicycles in overall count.

Interval Start	Heavy Vehicle Totals					Bicycles					Pedestrians (Crossing Leg)				
	EB	WB	NB	SB	Total	EB	WB	NB	SB	Total	East	West	North	South	Total
7:00 AM	2	4	0	3	9	0	0	0	0	0	1	0	1	0	2
7:15 AM	4	1	0	1	6	0	0	0	0	0	0	0	0	0	0
7:30 AM	11	16	0	1	28	0	0	0	0	0	0	0	0	0	0
7:45 AM	12	13	1	7	33	0	0	1	0	1	2	2	0	1	5
8:00 AM	7	12	0	8	27	0	0	0	0	0	0	0	1	0	1
8:15 AM	16	9	0	1	26	0	0	0	0	0	0	0	0	0	0
8:30 AM	11	8	2	3	24	0	0	0	0	0	0	1	0	0	1
8:45 AM	4	6	0	0	10	0	0	0	0	0	0	0	2	0	2
Count Total	67	69	3	24	163	0	0	1	0	1	3	3	4	1	11
Peak Hour	46	50	1	17	114	0	0	1	0	1	2	2	1	1	6

Two-Hour Count Summaries - Heavy Vehicles																		
Interval Start	Mill Plain Blvd				Mill Plain Blvd				92nd Ave				92nd Ave				15-min Total	Rolling One Hour
	Eastbound				Westbound				Northbound				Southbound					
	UT	LT	TH	RT	UT	LT	TH	RT	UT	LT	TH	RT	UT	LT	TH	RT		
7:00 AM	0	0	2	0	0	0	4	0	0	0	0	0	0	0	0	3	9	0
7:15 AM	0	0	4	0	0	0	1	0	0	0	0	0	0	0	1	0	6	0
7:30 AM	0	1	10	0	0	0	5	11	0	0	0	0	0	1	0	0	28	0
7:45 AM	0	2	10	0	0	0	2	11	0	1	0	0	0	6	0	1	33	76
8:00 AM	0	0	7	0	0	1	8	3	0	0	0	0	0	8	0	0	27	94
8:15 AM	0	1	15	0	0	0	9	0	0	0	0	0	0	1	0	0	26	114
8:30 AM	0	0	11	0	0	0	8	0	0	1	0	1	0	3	0	0	24	110
8:45 AM	0	0	4	0	0	1	4	1	0	0	0	0	0	0	0	0	10	87
Count Total	0	4	63	0	0	2	41	26	0	2	0	1	0	20	0	4	163	0
Peak Hour	0	4	42	0	0	1	24	25	0	1	0	0	0	16	0	1	114	0

Two-Hour Count Summaries - Bikes																		
Interval Start	Mill Plain Blvd			Mill Plain Blvd			92nd Ave			92nd Ave			15-min Total	Rolling One Hour				
	Eastbound			Westbound			Northbound			Southbound								
	LT	TH	RT	LT	TH	RT	LT	TH	RT	LT	TH	RT						
7:00 AM	0	0	0	0	0	0	0	0	0	0	0	0	0	0	0	0	0	0
7:15 AM	0	0	0	0	0	0	0	0	0	0	0	0	0	0	0	0	0	0
7:30 AM	0	0	0	0	0	0	0	0	0	0	0	0	0	0	0	0	0	0
7:45 AM	0	0	0	0	0	0	0	0	0	1	0	0	0	0	0	0	1	1
8:00 AM	0	0	0	0	0	0	0	0	0	0	0	0	0	0	0	0	0	1
8:15 AM	0	0	0	0	0	0	0	0	0	0	0	0	0	0	0	0	0	1
8:30 AM	0	0	0	0	0	0	0	0	0	0	0	0	0	0	0	0	0	1
8:45 AM	0	0	0	0	0	0	0	0	0	0	0	0	0	0	0	0	0	0
Count Total	0	0	0	0	0	0	0	0	0	1	0	0	0	0	0	0	1	0
Peak Hour	0	0	0	0	0	0	0	0	0	1	0	0	0	0	0	0	1	0

Note: U-Turn volumes for bikes are included in Left-Turn, if any.